

# LF120(-S) US / LF230(-S) US

On/Off, Spring Return Fail-Safe, 120/230 VAC



Technical Data		LF120(-S) US / LF230(-S) US
Power supply	LF120(-S) US	120 VAC ± 10% 50/60 Hz
	LF230(-S) US	230 VAC ± 10% 50/60 Hz
Power consumption		
	LF120(-S) US	running 5.5 W
		holding 3.5 W
	LF230(-S) US	running 5 W
		holding 3 W
Transformer sizing		
	LF120(-S) US	7.5 VA
	LF230(-S) US	7 VA
Electrical connection		3 ft, 18 GA appliance cable
(-S models have 2 cables)		1/2" conduit connector
Overload protection		electronic throughout 0 to 95° rotation
Electrical protection		actuators are double insulated
Angle of rotation		max 95°, adjust. with mechanical stop
Torque		35 in-lb [4 Nm] constant torque
Direction of rotation		reversible with cw/ccw mounting
Position indication		visual indicator, 0° to 95° (0° is spring return position)
Electrical protection		actuators are double insulated
Running time	motor	< 40 to 75 sec
(nominal)	spring	< 25 sec @ -4°F to 122°F [-20°C to 50°C] < 60 sec @ -22°F [-30°C]
Humidity		5 to 95% RH non-condensing
Ambient temperature		-22°F to 122°F [-30°C to 50°C]
Storage temperature		-40°F to 176°F [-40°C to 80°C]
Housing		NEMA type 2 / IP54
Housing material		zinc coated steel
Agency listings		cULus acc. to UL 873 and CAN/GSA C22.2 No. 24-93
Noise level (max)	running	< 50 db (A)
	spring return	62 db (A)
Servicing		maintenance free
Quality standard		ISO 9001
Weight	LF120/230	3.4 lbs (1.54 kg)
	LF120/230-S	3.5 lbs (1.60 kg)

LF120-S US / LF230-S US	
Auxiliary switch	1 x SPDT 3A (0.5A) @ 250 VAC, UL Approved adjustable 0° to 95°

**Torque min. 35 in-lb, for control of air dampers**

## Application

For On/Off, fail-safe control of dampers in HVAC systems. Actuator sizing should be done in accordance with the damper manufacturer's specifications. Control is On/Off from an auxiliary contact, or a manual switch.

The actuator is mounted directly to a damper shaft from 3/8" up to 1/2" in diameter by means of its universal clamp, 1/2" shaft centered at delivery. For shafts up to 3/4" use K6-1 accessory. A crank arm and several mounting brackets are available for applications where the actuator cannot be direct coupled to the damper shaft.

## Operation

The LF series actuators provide true spring return operation for reliable fail-safe application and positive close off on air tight dampers. The spring return system provides consistent torque to the damper with, and without, power applied to the actuator.

The LF series provides 95° of rotation and is provided with a graduated position indicator showing 0° to 95°.

The actuator may be stalled anywhere in its normal rotation without the need of mechanical end switches. Power consumption is reduced in holding mode. The actuator is double insulated so an electrical ground connection is not necessary.

The LF120-S US and LF230-S US versions are provided with 1 built-in auxiliary switch. This SPDT switch is provided for safety interfacing or signaling, for example, for fan start-up. The switching function is adjustable between 0° and 95°.

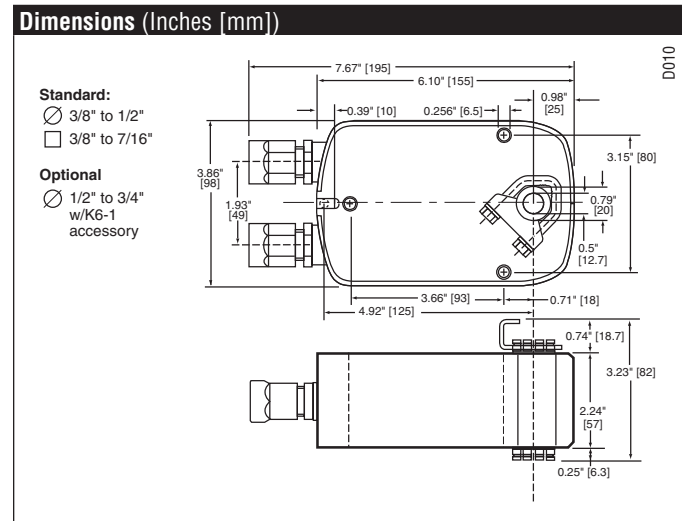

K20901 - 01/09 - Subject to change. © Belimo Aircontrols (USA), Inc.

### Accessories

AV 10-18	Shaft extension (K6-1 is required)
IND-LF	Damper position indicator
K6-1	Universal clamp for up to 3/4" diameter shafts
KH-LF	Crankarm for up to 1/2" round shaft
Tool-06	8mm and 10 mm wrench
ZG-LF2	Crankarm adaptor kit for LF
ZG-112	Mounting bracket for Honeywell Mod IV, M6415 type actuators, and new installations
ZG-LF112	Crankarm adaptor kit for Honeywell Mod IV, M6415 type actuators, and new installations
ZS-100	Weather shield (metal)
ZS-150	Weather shield (polycarbonate)
ZS-260	Explosion-proof housing

**NOTE:** When using LF120/230 US & LF120-S/230-S US actuators, only use accessories listed on this page. For Actuator Wiring Information and Diagrams, Please See Belimo Wiring Guide (pg 349).

### Typical Specification

On/Off spring return damper actuators shall be direct coupled type which require no crankarm and linkage and be capable of direct mounting to a shaft up to a 3/4" diameter and center a 1/2" shaft. The actuators must be designed so that they may be used for either clockwise or counterclockwise fail-safe operation. Actuators shall be protected from overload at all angles of rotation. If required, 1 SPDT auxiliary switch shall be provided having the capability of being adjustable. Actuators must be constructed to meet the requirements for Double Insulation so an electrical ground is not required to meet agency listings. Actuators shall be UL Approved and CSA certified, have a 5 year warranty, and be manufactured under ISO 9001 International Quality Control Standards. Actuators shall be as manufactured by Belimo.

### Wiring Diagrams

#### ✂ INSTALLATION NOTES

- 1 Provide overload protection and disconnect as required.
- 2 **CAUTION Equipment damage!**  
Actuators may be connected in parallel. Power consumption and input impedance must be observed.
- 3 No ground connection is required.
- 4 For end position indication, interlock control, fan startup, etc., LF120-S US and LF230-S US incorporate one built-in auxiliary switch: 1 x SPDT, 3A (0.5A) @250 VAC, UL Approved, adjustable 0° to 95°.

#### 📄 APPLICATION NOTES

- ◆ Meets cULus requirements without the need of an electrical ground connection.

#### ⚠ WARNING Live Electrical Components!

During installation, testing, servicing and troubleshooting of this product, it may be necessary to work with live electrical components. Have a qualified licensed electrician or other individual who has been properly trained in handling live electrical components perform these tasks. Failure to follow all electrical safety precautions when exposed to live electrical components could result in death or serious injury.

