

Note: Field Assembly of Hinge and Striker Catch to Duct Required.

MODEL DESCRIPTION:

Hinged door installs easily onto low pressure round duct providing convenient access. Strike and catch style closure and factory installed gasket ensure positive seal.

STANDARD CONSTRUCTION:

1. Duct Access Door 16 ga. (1.6) Galvanized Steel
2. Aluminum Piano Hinge
3. Strike and catch Zinc Plated Steel
4. Polyethylene Gasket
5. Other sizes are available; consult factory

SD-95 Round Access Door Dimension Chart			
Duct Diameter	Dimension "A"	Dimension "B"	# of Catches
5 (127)	7 (178)	4 (102)	2
6 (152)	8 (203)	5 (127)	2
7 (178)	9 (229)	6 (152)	2
8 (203)	10 (254)	7 (178)	2
9 (229)	11 (279)	8 (203)	2
10 (254)	12 (305)	9 (229)	2
12 (305)	14 (356)	10 (254)	2
14 (356)	16 (406)	12 (305)	2
16 (406)	16 (406)	12 (305)	3
18 (457)	18 (457)	14 (356)	3
20 (508)	18 (457)	16 (406)	3
24 (610)	18 (457)	16 (406)	4

Dimensions in Inches (mm)

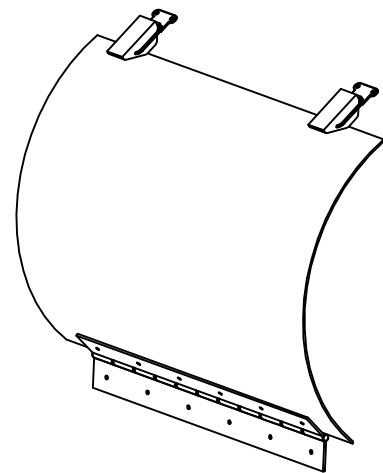

Job Name:	<input type="checkbox"/> MODEL SD-95		
Location:			
Architect:	DRAWN BY: MHM	DATE: 7-1-09	REV. DATE: 5-6-14
Engineer:	REV. NO. 5	APPROVED BY: SDC	DWG. NO.: J-2
Contractor:			