



**AIR PRODUCTS AND CONTROLS INC.**  
**INSTALLATION AND MAINTENANCE INSTRUCTIONS**  
**FOR HS-100 SERIES DUCT SMOKE DETECTORS**  
**NO-FLOW • LOW-FLOW • SPECIAL APPLICATION**

**HS-100-N** 4-Wire, Ionization Type  
**HS-100-P** 4-Wire, Photoelectric Type

**PRODUCT OVERVIEW**

**PRODUCT APPLICATION**

HS-100 Series duct smoke detectors provide early detection of smoke and products of combustion present in air moving at no or low flow through an HVAC duct supply, return, or both in commercial, industrial, and residential applications. These devices are designed to prevent the recirculation of smoke in areas by the air handling system's fans and blowers. Complete systems may be shut down in the event of smoke detection.

The HS-100 is designed specifically for applications where our standard external mount duct detectors cannot be utilized. Examples include air shafts, plenum spaces or applications requiring extremely low or no air velocity  $\leq 100$  ft/min.

**NOTE:** For the correct installation of a duct smoke unit, please refer to the NFPA 72 (National Fire Alarm Code), NFPA 90A (Standard for Installation of Air Conditioning and Ventilation Systems), NFPA 92A (Recommended Practice for Smoke Control Systems.), NFPA 5000 (Building Construction and Safety Code), IMC (International Mechanical Code), and IFC (International Fire Code).

This detector is not intended for open area protection nor should it be used for early warning detection or replace a regular fire detection system.

**PRODUCT DESCRIPTION**

The HS-100 Series smoke detector is fitted with a mounting base that will accept an ionization smoke detector head model 55000-225 or photoelectric smoke detector head model 55000-328. The duct unit supports one set of form "C" alarm contacts, one form "A" alarm contact and one form "B" trouble contact. The trouble contact supervises the presence of the input power and the removal of the smoke detector head.

The trouble contacts **will not** operate in the event of a smoke alarm. The HS-100 Series duct detector will operate from various input voltage sources; namely 24VAC, 24VDC, 115VAC and 230VAC.

**SAMPLING**

The operating principle of this duct detector is based on air flowing through the duct and passing over the detector head. When the concentration of smoke particles suspended in the air stream reach the alarm threshold of the detector head, the unit will go into alarm.

The duct smoke detector units are designed to operate in spaces with an air velocity between 0 to 3,000 feet per minute. To verify correct installation, the air velocity should be measured using a velocity meter. An acceptable reading is between 0 and 2,000 ft/min for the HS-100-N; between 0 and 3,000 ft/min for the HS-100-P.

To minimize the impact of air turbulence and stratification on performance, a duct smoke detector should be located as far as possible downstream from any obstruction (i.e. deflector plates, elbows, etc.). In all situations, confirmation of velocity is required.

**REMOTE ACCESSORIES**

Audible and visual alarm indicators, remote status indicators, and remote reset/test switches can be accommodated by the HS-100 Series duct units by connecting to DC voltage output terminals as described on Page 3. These terminals are not supervised and the voltage/current will only be present when the detector unit is in alarm. The remote pilot (green) LED will be permanently illuminated when connected to the output terminals as long as input power and detector head are present.

**HS-100 AT-A-GLANCE**

**MODEL NUMBER:**

HS-100-N 4-Wire Ionization Duct Smoke Detector  
HS-100-P 4-Wire Photoelectric Duct Smoke Detector

**DETECTOR HEAD MODEL NUMBER:**

Ionization Detector Head: **55000-225**  
Photoelectric Detector Head: **55000-328**

**POWER REQUIREMENTS:** **60 Hz**

STANDBY CURRENT		ALARM CURRENT	
24VAC	54.4mA	24VAC	139mA
24VDC	15mA	24VDC	48mA
115VAC	31mA	115VAC	34mA
230VAC	18mA	230VAC	20mA

**UNIT RATINGS:**

- Alarm contacts: 1 Set form "C" rated at 10A@115VAC resistive  
1 form "A" rated at 2A
- Trouble contact: 1 form "B" rated at 10A @ 115VAC resistive
- Air velocity: 0 to 3,000 ft/min.
- Ambient temperature: HS-100-N: 32°F to 158°F (0°C to 70°C)  
HS-100-P: 32°F to 140°F (0°C to 60°C)
- Humidity: 0% to 85% RH Non-Condensing/Non-Freezing
- Material: White plastic base/housing and detector (Makrolon 94V-0)
- Dimensions: 6.0" Dia X 4.0" H Overall / 2.6" H from back box front
- Max. net wt.: 1.0 lb.
- Radioactive element: HS-100-N (Ionization) - Americium 241, 0.9 micro curie.
- Mounting: Standard 4" square back box (by others)

**Do not expose to corrosive atmospheres.**

# MECHANICAL INSTALLATION

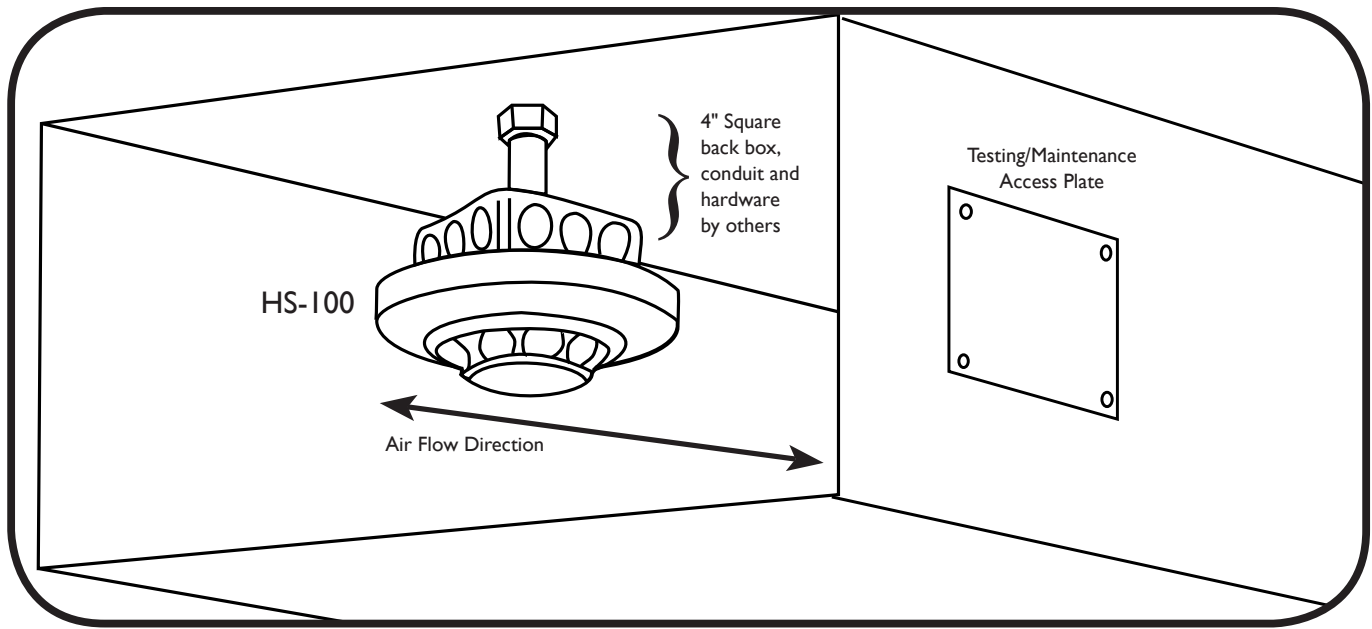

**Note:** Mounting shown is typical for an installation conduit pendant mounted on a standard 4" square electrical box.

## LOCATION PREREQUISITES

This guideline contains general information on duct smoke detector installation, but does not preclude the NFPA and/or ICC documents listed. Air Products and Controls assumes no responsibility for improperly installed duct detectors. To determine the correct installation position for an HS-100 Series duct smoke detector, the following factors must be considered.

- 1) A uniform non-turbulent (laminar) airflow between 0 ft/min. to 3,000 ft/min. must be present in the HVAC duct. To determine duct velocities, examine the engineering specifications that define the expected velocities or use an Alnor model 6000AP velocity meter (or equivalent).
- 2) To minimize the impact of air turbulence and stratification on performance, a duct smoke detector should be located as far as possible downstream from any obstruction (i.e. deflector plates, elbows, etc.). In all situations, confirmation of velocity within specifications is required.
- 3) Identify a code compliant location (supply or return side, or both) for the installation of the duct unit that will permit easy access for inspection and serviceability.
- 4) When installing on the return side, install duct units prior to the air being exhausted from the building or diluted with outside "fresh" air.
- 5) When installing duct smoke units downstream of filters, fires occurring in the filters will be detected, but if the filters become blocked, insufficient air flow through the duct unit will prevent the correct operation of the duct detector. Duct units installed in the supply air side may monitor upstream equipment and/or filters.

6) Where possible, install duct detectors upstream of air humidifiers and downstream of dehumidifiers.

7) To prevent false alarms, the duct detector should not be mounted in areas of extreme high or low temperatures, in areas where high humidity exists, or in areas where the duct may contain gases or excessive dust.

## MOUNTING

Remove the detector from its twist-in base. Remove the two mounting base plate-to-shroud screws. After securing the mounting base plate to the 4" square back box, wire the mounting base plate as appropriate. Re-assemble the shroud/detector base to the mounting base plate. Re-install the detector head. Proceed to testing.

# ELECTRICAL INSTALLATION

## TERMINAL AND POWER CONNECTIONS

Prior to connecting input power to the duct unit, determine the correct input voltage/current availability and ensure it is connected to the correct terminals.

**CAUTION:** Do not use looped wire under terminals. Break wire run to provide for proper supervision of connections.

### DRY CONTACT OUTPUTS

#### ALARM

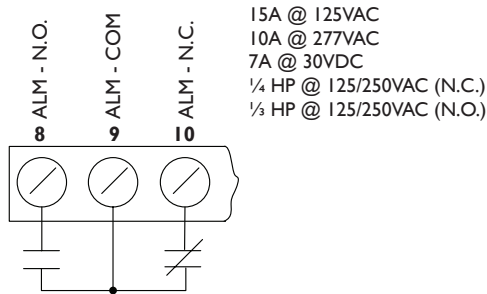

#### FACP

\* Trouble contacts shown in "normal" unit energized state

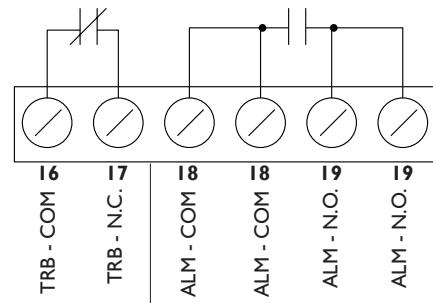

### OPERATING POWER INPUTS

#### HIGH VOLTAGE

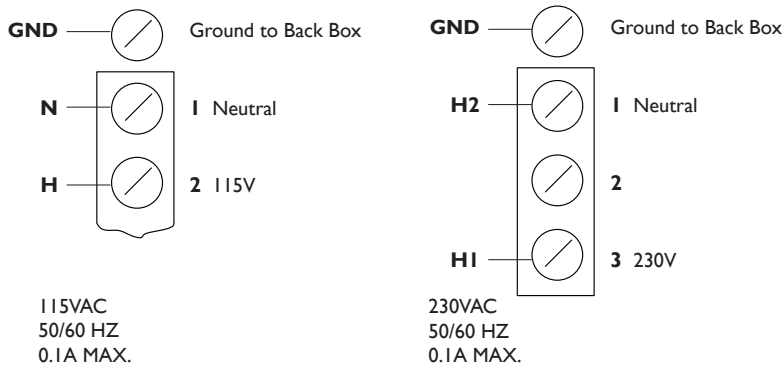

#### LOW VOLTAGE

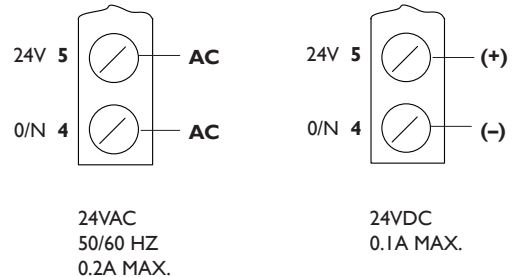

### REMOTE ACCESSORY OUTPUTS

#### MSR-SERIES

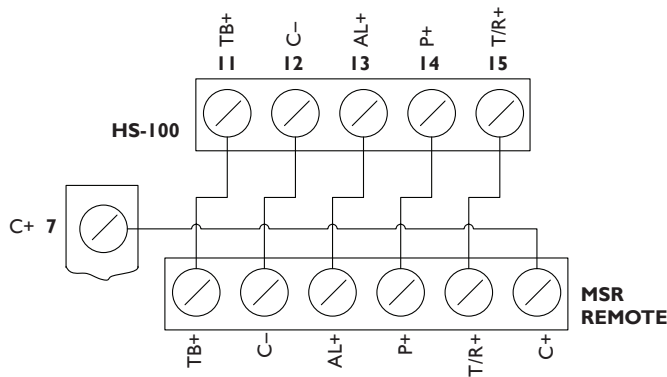

#### MS-SERIES

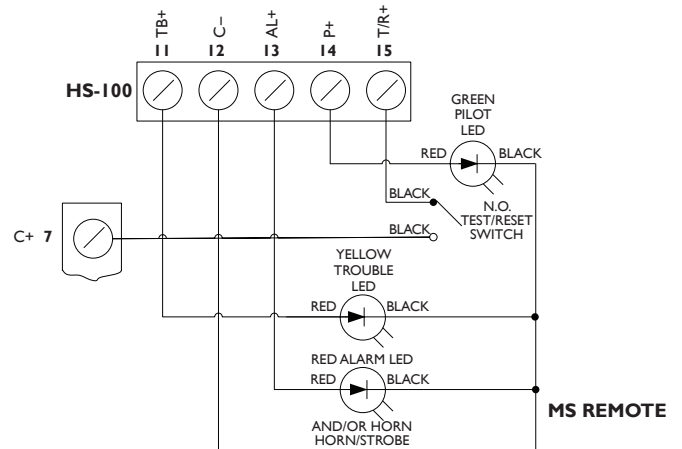

## WIRING

In the event of a fire alarm, certain equipment may be required to be shut down. For example, shut down may be achieved by interrupting the supply source to that particular piece of equipment when wired as indicated on Page 4.

# ALARM CONTACT USE EXAMPLE

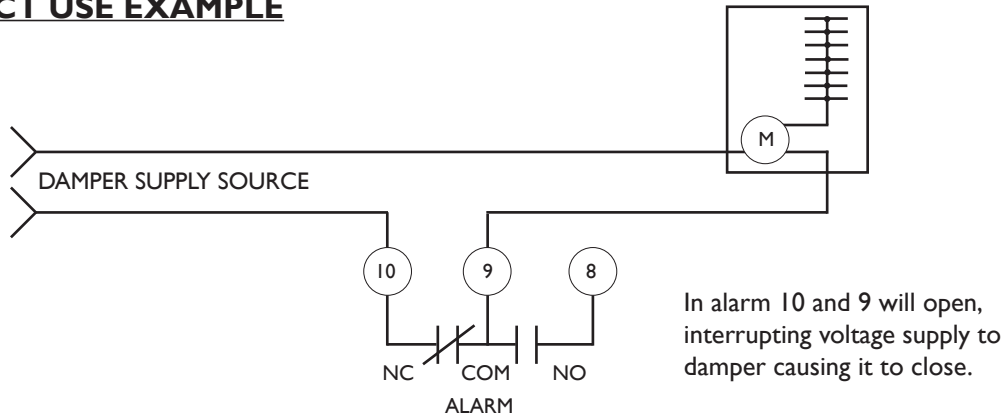

# FIRE ALARM CONTROL PANEL WIRING

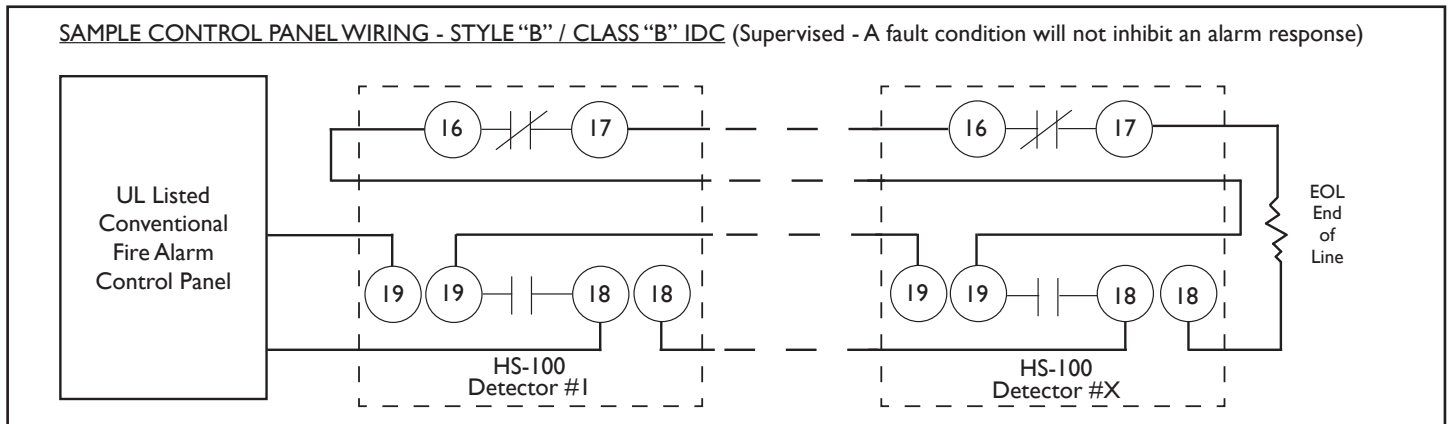
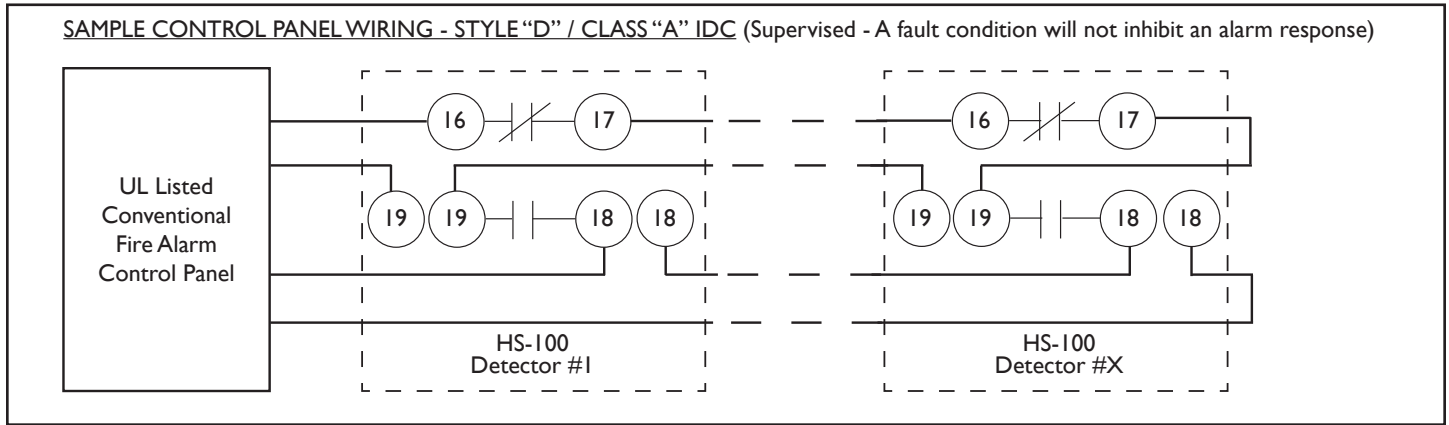

# INTERCONNECTION WIRING FOR COMMON FUNCTIONS

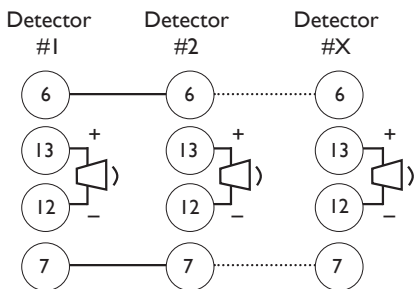

All alarm relays operate with single alarm. Individual horn/strobe units operate on alarmed detector only. 30 detectors max.

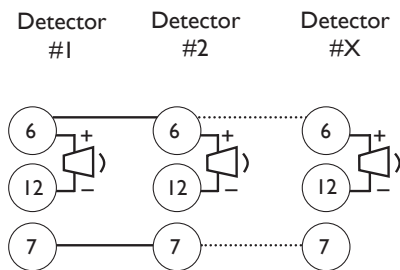

All alarm relays operate with single alarm. All horn/strobe units operate on any single alarm. 10 detectors max.

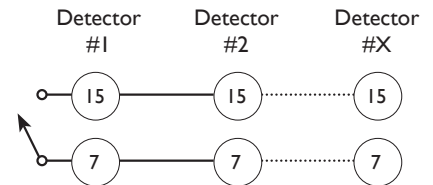

Common test/reset. 30 detectors max. (Use normally open test/reset switch)

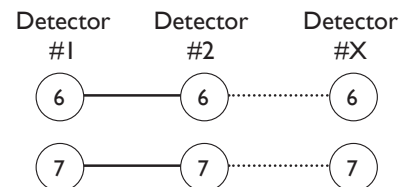

All alarm relays operate with single alarm. 30 detectors max.

**NOTE:** A common power supply must be used for all interconnected detectors.

# TESTING AND MAINTENANCE PROCEDURES

## **OPERATIONAL TESTING**

To determine the correct operation of the HS-100 Series duct smoke detector, ensure input power is connected and the LED on the detector head of both the ionization and photoelectric models is flashing while the unit is in standby mode. The LED on the smoke detector head will be permanently illuminated when smoke is detected and the head is in alarm.

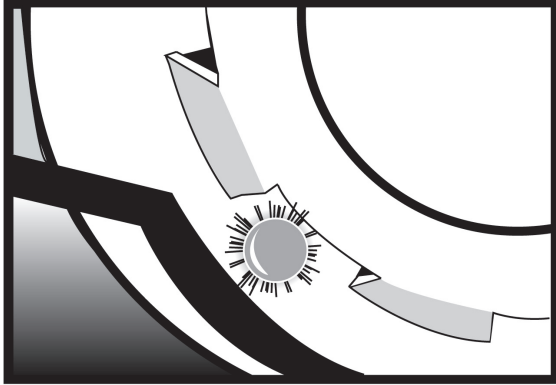

Above: The LED will be permanently illuminated when the unit is in alarm.

Cause a detector alarm via magnet or smoke testing procedures detailed under functional testing below with the air handling unit shut down (not connected). The red alarm LED on the detector will be illuminated and the alarm relay outputs will change state. Using a multimeter set to OHMS (or continuity buzzer function on the meter) place the meter probes on the following terminals, and ensure the contacts are closed (continuity) (19-18) and (8-9). When removing the magnet or clearing the detector chamber of test gas and twisting the head loose manually and locking it back into position these contacts will again open and the unit will be back in the normal standby state.

The trouble contacts (16,17) on the HS-100 detector will not change state in the event of a fire alarm, operational, or functional testing. The trouble contacts can be tested by rotating the smoke detector head counter-clockwise or completely removing the detector head. This action will extinguish the flashing red LED and cause the trouble contacts to change state, and (16-17) will be open circuit. Replacing the detector head and rotating it clockwise until it locks will cause the red LED to be illuminated flashing and the unit will be operational; terminals (16-17) will be closed (continuity).

## **FUNCTIONAL TESTING**

Once operational testing is concluded the unit requires functional testing to determine the correct operation of the detector head.

**MAGNET TESTING:** Place the magnet provided with the installation kit on top of the shroud or detector head roughly opposite the LED. Allow at least five seconds for alarm initiation. Remove magnet and reset detector.

**SMOKE TESTING:** Using smoke test canister with spray testing nozzle (available from Air Products and Controls Inc. part number TG-1000), spray the test gas into the detector.

**⚠ CAUTION: DO NOT SPRAY GAS FOR MORE THAN ½ SECOND. OVERUSE OF TEST GAS FACILITY MAY RESULT IN DETECTOR CONTAMINATION.**

After 15 to 20 seconds the detector head will go into alarm, illuminating the detector head LED and causing the duct unit functions to operate, alarm relays will change state, and the alarm related remote accessories, if attached, will function.

If no test gas is available to conduct functional testing, blow smoke from a cotton wick or punk directly at the head to cause an alarm. The alarm indicator should illuminate within one minute.

Should additional testing also be required for simulated fire conditions, smoke bombs placed in the duct may not be suited for the particular detector head (photoelectric or ionization) selected and installed. Consult the smoke bomb data for proper use and compatibility with detector type.

The S65A ionization detector head (55000-225) utilizes a radioactive source as its means of detection and will detect smoke particles of between .1 and 1 micron in size.

The S65A photoelectric detector head (55000-328) operates on the principle of light scatter and will detect smoke particles of between 1 and 10 microns in size.

When purchasing smoke bombs for additional required functional testing, ensure smoke particle sizes comply with the criteria as described above.

**NOTE:** In situations that require a duct smoke detector to be held in an alarm condition for an extended period of time, the magnet test or smoke test methods should be used to ensure the detector is locked into alarm.

## **MAINTENANCE**

Each installation location must be assessed on its own merits. If the protected area is of a very dirty nature then the HS-100 duct unit(s) will have to be checked and cleaned on a quarterly basis or when cleaning is required.

As a guideline the smoke detector head should be cleaned every six months or as required. The best methods of cleaning are to vacuum the detector head thoroughly or to blow the detector head out using clean, dry compressed air.

Do not use chemicals or non-conforming air to clean the detector head housing as this could contaminate the detector head and damage the casing.

Consult your local code and AHJ requirements for required maintenance schedules.



AIR PRODUCTS AND CONTROLS INC.  
1749 E. Highwood • Pontiac, MI 48340 USA  
Telephone: (248) 332-3900 • www.ap-c.com

Technical Support: (888) 332-8807

## AVAILABLE ACCESSORIES FOR USE WITH HS-100 SERIES DUCT SMOKE DETECTORS

### MSR- SERIES REMOTE ACCESSORIES

Visual Indicators: Alarm, Pilot, Trouble • Buzzer: Programmable for Alarm and Trouble  
Buzzer Silence: Visual Notification and Ringback • Detector Test/Reset: Key Operated  
LED/Buzzer Test: Push-Button Operated

- MSR-100R/VV White Face Plate
- MSR-100R/R Red Face Plate
- MSR-100R/S Stainless Steel Face Plate
- MSR-100RS/W/C White Face Plate; Strobe with Clear Lens
- MSR-100RS/W/O White Face Plate; Strobe with Opaque Lens
- MSR-100RS/R/C Red Face Plate; Strobe with Clear Lens
- MSR-100RS/R/O Red Face Plate; Strobe with Opaque Lens
- MSR-100RS/S/C Stainless Steel Face Plate; Strobe with Clear Lens
- MSR-100RS/S/O Stainless Steel Face Plate; Strobe with Opaque Lens

### MS- and SHP- SERIES REMOTE ACCESSORIES

- MS-RA Remote Alarm
- MS-RA/R Remote Alarm, push button Test/Reset Switch
- MS-RA/P/R Remote Alarm, Pilot, push-button Test/Reset Switch
- MS-KA/R Remote Alarm, key-operated Test/Switch
- MS-KA/P/R Remote Alarm, Pilot, key-operated Test/Reset Switch
- MS-RA/P Remote Alarm, Pilot
- MS-RH Remote Alarm Horn
- MS-RH/K/A/P/R Remote Alarm, Pilot, Horn, key-operated Test/Reset Switch
- MS-RH/P/A Remote Alarm, Pilot, Horn
- MS-RH/K/A/P/A/T Remote Alarm, Trouble, Pilot, Horn, key-operated Test/Reset Switch
- MS-RA/P/T Remote Pilot, Trouble
- MS-RA/FT/P Remote Pilot, Trouble, push-button Test/Reset Switch
- MS-KA/P/R/T Remote Pilot, Trouble, key-operated Test/Reset Switch
- MS-RD Remote Alarm
- MS-FT Remote Trouble
- SHP24-1575R Horn/Strobe, red housing, clear cover
- SHP24-1575O Horn/Strobe, white housing, opaque cover
- SHP24-1575W Horn/Strobe, white housing, clear cover

### SMOKE TEST GAS

TG-1000 Solo Aerosol Test Gas with Spray Nozzle

### REPLACEMENT SMOKE DETECTOR HEADS

- 55000-225 S65 Ionization Detector Replacement Head
- 55000-328 S65 Photoelectric Detector Replacement Head

### POWER SUPPLIES

- T-PB 202-1 24VAC @ 4.0A Class I Power Supply
- T-PB 202-0 24VAC @ 4.0A Class I Power Supply
- T-PB 303-1 24VAC @ 3.0A Class I Power Supply
- T-PB 303-0 24VAC @ 3.0A Class I Power Supply

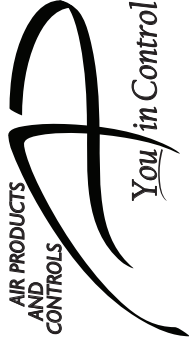

## HS-100 SERIES DUCT SMOKE DETECTORS

NO-FLOW • LOW-FLOW • SPECIAL APPLICATION

## INSTALLATION AND MAINTENANCE INSTRUCTIONS



- HS-100-N** 4-Wire, Ionization Type
- HS-100-P** 4-Wire, Photoelectric Type

NOTICE: The information contained in this document is the most current, available at the time of shipment of accompanying product, and is subject to change without notice. Future references should always be made to the most current revision of this document. The information contained in all this document should be considered before installing or using the product. Any example applications shown are subject to the most current enforced local/national codes, standards, approvals, certifications, and/or the authority having jurisdiction. All of these resources, as well as the specific manufacturer of any shown or mentioned related equipment, should be consulted prior to any implementation. For further information or assistance concerning this product, contact Air Products and Controls Inc. Air Products and Controls Inc. reserves the right to change any and all documentation without notice.  
© Air Products and Controls Inc. 2006

**A COPY OF THESE INSTRUCTIONS SHOULD BE LEFT WITH THE EQUIPMENT UNTIL  
INSTALLATION BY ALL TRADES IS FULLY COMPLETE. FOLLOWING FINAL INSPECTION,  
A COPY SHOULD BE LEFT WITH THE OWNER/USER.**

**FOR TECHNICAL SUPPORT CALL TOLL FREE 888-332-2241 OR 248-332-3900**