



### Application and Design

The ICBL-R is designed for protection against sudden blasts and instantaneous pressure changes.

#### STANDARD CONSTRUCTION:

**FRAME:**  
 10" deep 10 ga. Carbon Steel Channel with 8" wide x 1/4" Faceplate

**BLADE:**  
 10 ga carbon steel

**BLADE LOCK:**  
 Latch mechanism to lock blades in close position after Blast (exothermic reaction)

**AXLE:**  
 Ø 3/4" solid A36 steel

**LINKAGE:**  
 3/16" thick x 3/4" wide bars

**BEARINGS:**  
 (type II) two hole flange ball bearing

**FINISH:** Zinc Rich Primer (ready to paint)  
**SIZE LIMITATIONS:**  
 minimum size: 6" Ø  
 maximum size: 12" Ø (see graph for psi limitations)

Specify:  
 Airflow direction and cfm

8" wide, 1/4" plate factory stitch welded to damper frame

Equalizing Grid (G-ICBL-R only)

#### VARIATIONS:

- Blade seals (EDPM)
- Blade seals (silicone)
- 304 Stainless Steel construction
- 316 Stainless Steel construction
- Powder Coating, Color Select
- Equalizing Grid (G-ICBL-R)

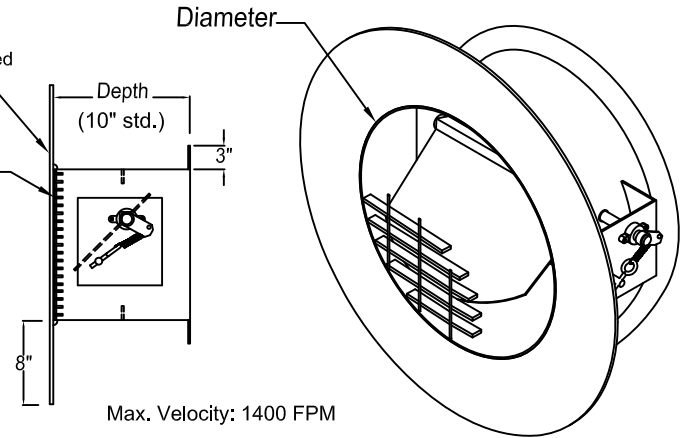

Note: G-ICBL-R Damper Shown

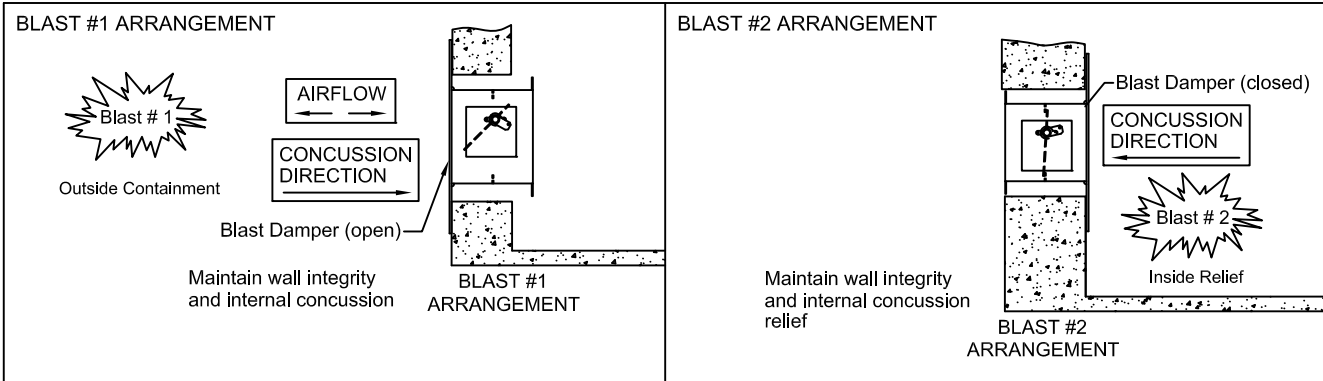

### SUGGESTED SPECIFICATION

Furnish and install, at locations shown in plans or in accordance with schedules, industrial grade blast dampers meeting the following construction standards. Frame shall be 8" to 12" deep (10" std.) x 3" flanged 10 gage carbon steel channel. Sleeve or channel with inner frame is not acceptable. The blades shall be minimum 10 gage steel with "V" formed at axles. Axles shall be continuous (not axle pins) 3/4" diameter welded to blade. Bearings shall be Type II, 2 hole ball bearing at axles and bolted to frame. Linkage shall be minimum 3/16" thick located on side of damper out of airstream. Pivot pins in linkage shall be stainless steel. Linkage shall include externally mounted release springs and adjustable tension to keep damper open until blast of specified pressure force blades closed. Damper shall include blade locks for delayed exothermic reaction (a moving flame front). Damper shall be designed to withstand blast of up to \* \_\_\_\_\_ psi with blades closed. Damper must be installed per manufacturer installation instructions. Damper shall be United Energetech ICBL-R blast damper. Finish shall be powder coated gray.

\*See graph for size (diameter) and design pressures (psi)

Due to continuing research, UE reserves the right to change specifications without notice.

Job Name:	<input type="checkbox"/> <b>ICBL-R (Round Blast Damper)</b> <input type="checkbox"/> <b>G-ICBL-R (Round Blast Damper)</b>		
Location:	DRAWN BY:	DATE:	REV. DATE:
Architect:	CLJ	12-30-09	1-26-11
Engineer:	REV. NO.	APPROVED BY:	DWG. NO.:
Contractor:	5	SDC	<b>C-36</b>

# ICBL-R INSTALLATION INSTRUCTIONS

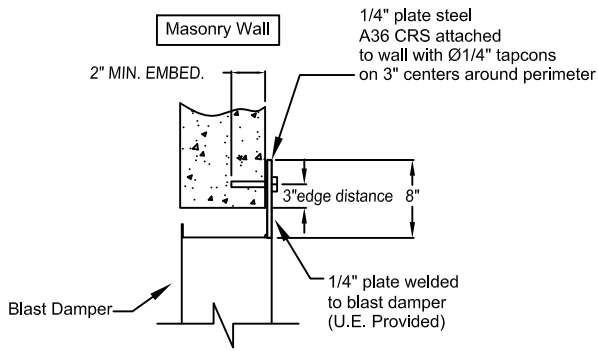

PLATE STRESS (ksi) 3/4" AXLE = 12.3 ksi

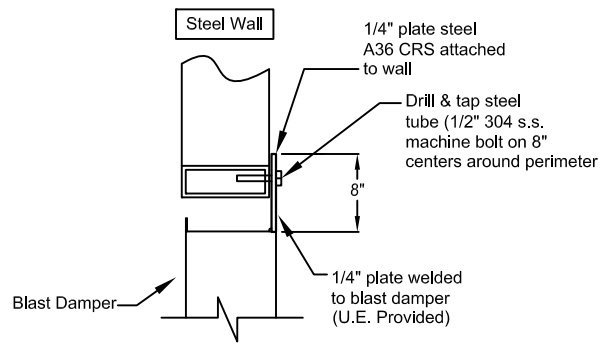
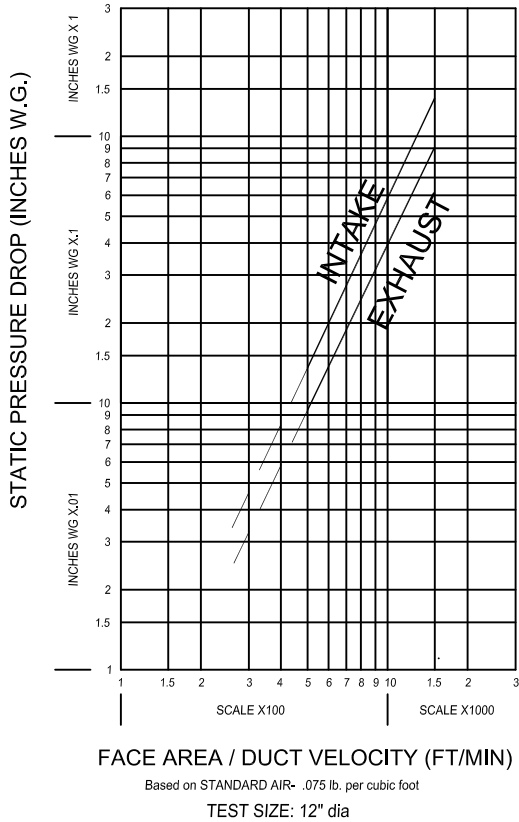

PLATE STRESS (ksi) 3/4" AXLE = 12.3 ksi

Note: Attachment is to be made on the same side as the blast  
Substrates may vary from above application; site specific engineering may be required.

## PRESSURE DROP



## ROUND BLAST DAMPERS (ICBL-R) DESIGN PRESSURES VS. DIAMETER

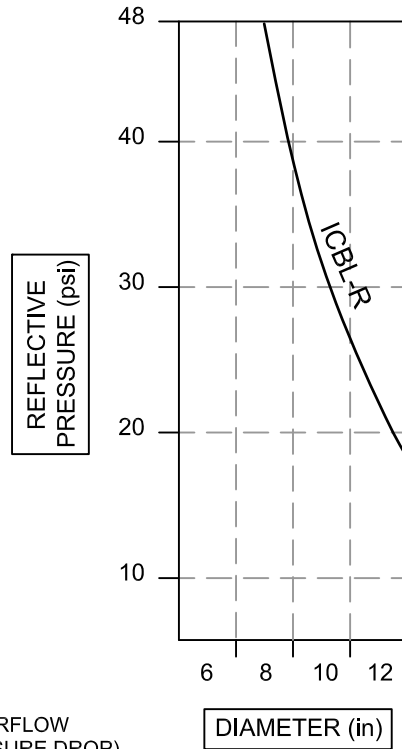

DIRECTION OF AIRFLOW  
(SEE CHART FOR PRESSURE DROP)

