



MODEL F/S-3V-II & F/S-3V-3-II

COMBINATION FIRE/SMOKE DAMPER

U.L. 555 and U.L.C. S112 Listed 1-1/2 and 3 Hour Rated

U.L. 555S and U.L.C. S112.1 Listed Class II Leakage

UL File No.
R25410

Standard Construction:

- Frame:** Roll-formed galvanized steel hat-section with staked corners with integral bracing.
- Blades:** 16ga. Roll-formed galvanized steel.
Minimum width: 4.250" (108mm)
Maximum width: 7.250" (184mm)
- Bearings:** Bronze Oilite, press-fit into frame.
- Axles:** Square, plated steel.
- Seals:** Pressure sensitive 450° F silicone blade edge seals and flexible metal jamb seals.
- Linkage:** Concealed in frame. Linkage bars are .125" (3.2mm) thick plated steel.
- Controlled Closure Devices:** (Heat Activated)
EFL - 165° F Standard, 212°, 250°, 350° F available
PFL - 165° F Standard, 212° F available
- Finish:** Mill galvanized.
- Maximum Velocity:** 2000 fpm (10.2 m/s) on all sizes
- Maximum Pressure:** 4" wg (1kPa)

Sizes:

- Minimum Size:** 6"w x 6"h (152mm x 152mm)
- Max - Single Section:** 36"w x 48"h (914mm x 1219mm)
- Max - 1-1/2hr. Vertical:** 108"w x 96"h (2743mm x 2438mm)
- Max - 1-1/2hr. Horizontal:** 72"w x 48"h (1828mm x 2438mm)
- Max - 3hr. Vertical:** 72"w x 48"h (1828mm x 1219mm)
- Max - 3hr. Horizontal:** 72"w x 48"h (1828mm x 1219mm)

Features:

- The F/S-3V-II or F/S-3V-3-II series Combination Fire/Smoke Dampers have been designed and tested to exceed all U.L., U.L.C. and N.F.P.A. requirements for fire dampers as well as smoke dampers.
- F/S-3V-II is U.L. 555 and U.L.C. S112 listed and labeled as a 1-1/2 hour fire damper.
- F/S-3V-3-II is U.L. 555 and U.L.C. S112 listed and labeled as a 3 hour fire damper.
- U.L. and U.L.C. listed for both vertical and horizontal mountings.
- U.L. 555S / U.L.C. S112.1 listed and labeled as a Leakage Class II rated Smoke Damper with airflow in both directions. Class II provides for a maximum leakage of 20 cfm per sq. ft. at 4.0 inches static pressure.

Notes: •Non-Sleeved dampers with side plate are furnished approximately 1/4" (6.4mm) smaller than given duct dimensions. Sleeved dampers are furnished approx. same size as given duct dimension, unless otherwise noted.

•It is recommended the damper must be inspected and cycled at intervals not greater than every twelve months or in accordance with NFPA 80, 90A, 92A, local codes and the actuator manufacturer.

Suggested Specification

Combination Fire/Smoke Dampers shall be Model: F/S-3V-II, by United Enertech. Fire/Smoke Dampers shall bear the Underwriters' Laboratories labels for both Fire Dampers and Smoke Dampers. U.L. 555S / U.L.C. S112.1 rating shall be Class II with leakage not to exceed 20 cfm per sq. ft. at 4.0 inches static pressure for any size. Linkage shall be of the concealed type for maximum free area.

U.L. 555S CLASSIFIED
AT 250 °F OR 350 °F
DEPENDING UPON
MOTOR/OPERATOR
*SEE MOTOR/OPERATOR SCHEDULE

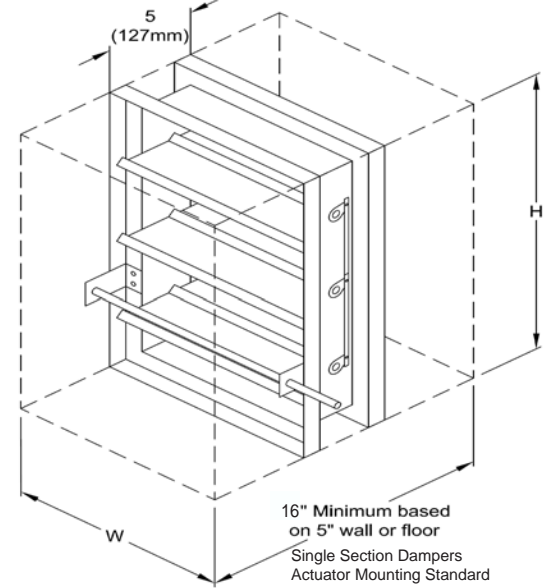

Options:

- Factory sleeves _____ Ga, (20 Ga minimum)
Length _____ (min. 16")
(16" X 20 ga. side plate provided if no sleeve is indicated)
- Retaining Angles
 - One Side
 - Both Sides
- Smoke Detector
 - Ionization
 - Photoelectric
- Transitions
 - Round
 - Oval
- DTO/RE w/ MS Package
- Micro-Switch Package
- RCB-1, -2, -3
- Actuator
 - Electric, _____ VAC (Voltage)
 - Pneumatic. 25 psi
- Grille Mtg. - 3/4" Mounted Face Flange
 - Shipped loose (if external actuator)
- Mounting Orientation
 - Horizontal
 - Vertical

Name:	<input type="checkbox"/> MODEL F/S-3V-II (1-1/2 hour)		
Location:	<input type="checkbox"/> MODEL F/S-3V-3-II (3 hour)		
Architect:	DRAWN BY: MAB	DATE: 11-12-07	REV. DATE: 10-20-11
Engineer:	REV. NO. 6	APPROVED BY: SDC	DWG. NO.: B-2
Contractor:			

PERFORMANCE DATA

Pressure drop testing was done by an independent laboratory to the AMCA Standard 500-D, Fig. 5.3 ductwork upstream & downstream.

DAMPER SIZE 36 x 36

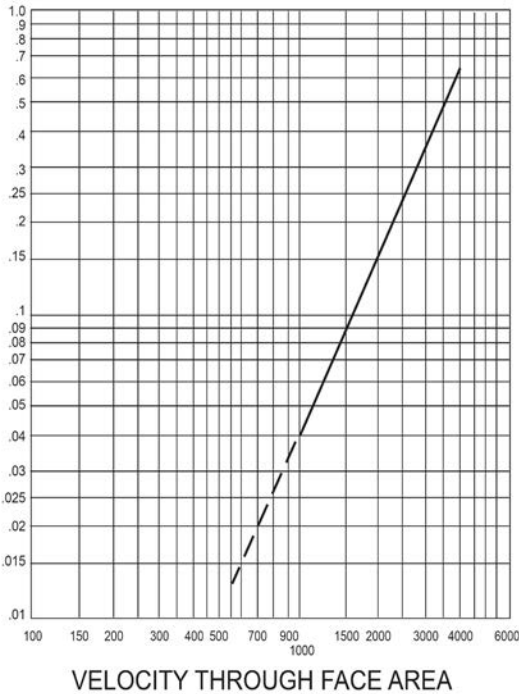

DAMPER SIZE 24 x 24

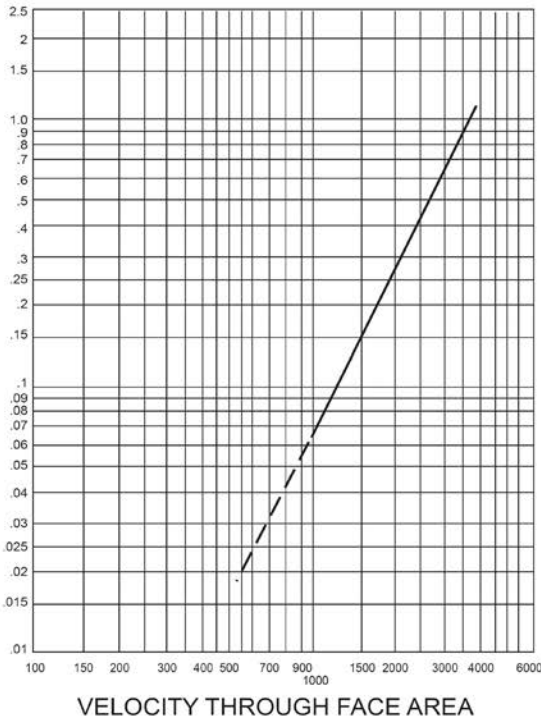

DAMPER SIZE 12 X 12

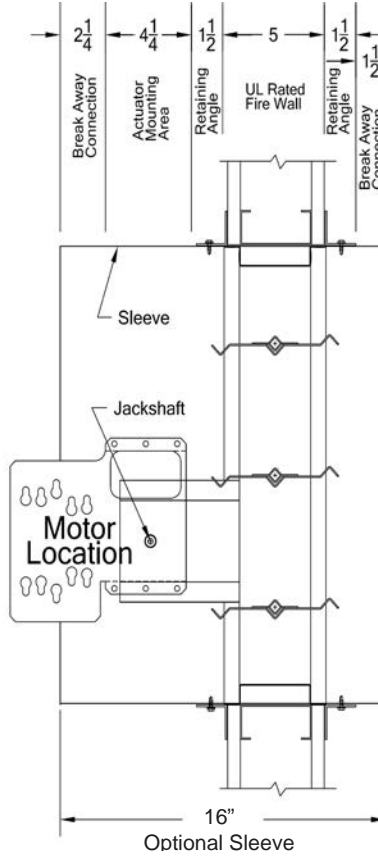
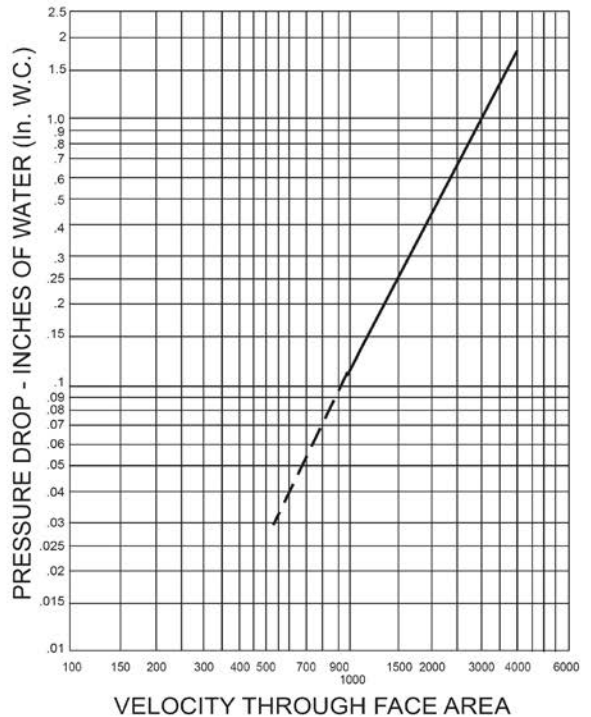

When the actuator is externally mounted and the wall thickness exceeds 5 inches, add 1 inch for each additional inch of wall thickness increased to ensure sleeve length through the penetration. As standard the actuator is externally installed on the lower right hand half of the damper when viewed from the jack shaft side. The damper may be installed/rotate 180° such the actuator will be located on the upper left. The top of the damper is either side of the frame as long as the blades are running horizontal. When ordering internally mounted actuators, be aware there is a min. height requirement (in some cases the sleeve can be increased to allow for internally mounting). The entire damper frame does not have to be installed in the plane of the wall of floor. The rule of thumb is with the damper in the closed position, the blade plane should be within the plane of the UL rated wall or floor.