

SUBMITTAL DATA

MODEL ES-EL-6

6" [152mm] Aluminum Equipment Screen

STANDARD CONSTRUCTION:

FRAME: 2" x 2" x 0.25" [51mm x 51mm x 6.35mm]thk. angle (6063-T5 Extruded)

BLADES: 0.110" [2.79mm] thk., 6063-T5 Extruded Aluminum

FINISH: Mill

MAX. SINGLE SECTION: 84"w x 120"h or 120"w x 84"h [2134mm x 3048mm or 3048mm x 2134mm]

MIN. SECTION SIZE: 12"w x 12"h [305mm x 305mm]

*Panels over 48" [1219mm] wide will have a 2" x 2" x 0.25" [51mm x 51mm x 6.35mm] aluminum angle with blade supports mid-span.

AVAILABLE FINISHES:

- Powder Polyester TGIC** (2 coats) baked on at 410°F [210° C], 2.5 to 3.5 mils Meets AAMA-2603 Standards
- Powder Super durable polyester** (2 coats) baked on at 410°F [210° C], 2.5 to 3.5 mils Meets AAMA-2604-05 Standards
- Acrylic baked enamel (ACRA-BOND® ULTRA)** by AkzoNobel baked on at 350°F [117° C], 0.8 to 1.2 mils dry Meets AAMA-2603 Standards
- Kynar® (ALUM*A*STAR®)** 2 coats by AkzoNobel baked on at 450°F [232° C], 1.2 to 1.6 mils dry Meets AAMA-2604-05 Standards
- Kynar 500® or HYLAR® 5000 70% TRINAR®** (2 coats) by AkzoNobel baked on at 450°F [232° C], 1.2 to 1.6 mils dry, Meets AAMA-2605-05 Standards
- Kynar 500® or HYLAR® 5000 (70% Tri-Escent II)** (2 coats) by AkzoNobel, a superior finish to other metallic or anodized finishes. A blend of mica, ceramic, and inorganic pigments creates subtle yet dazzling design that goes beyond metallic color without the requirement of a clear coat. 14 standard colors - custom colors available. Baked on at 415°F [213° C], 1.4 to 1.8 mils dry, meets AAMA 2605-05.
- Clear Anodize 204 R-1 Class II (AA-C22A31)** (0.4 to 0.7 mil)
- Clear Anodize 215 R-1 Class I (AA-C22A41)**(>0.7 mil)
- Integral Color Anodize (AA-C22A42)**(>0.7 mil)
 - Clear coat available for all above finishes.
 - Hylar® 5000 is a registered trademark of Solvay Solexis, Inc.
 - Kynar® 500 is a registered trademark of Arkema.
 - ALUM*A*STAR® 50 and TRINAR® are registered trademarks of AkzoNobel
 - ACRA-BOND® ULTRA is a registered trademark of AkzoNobel

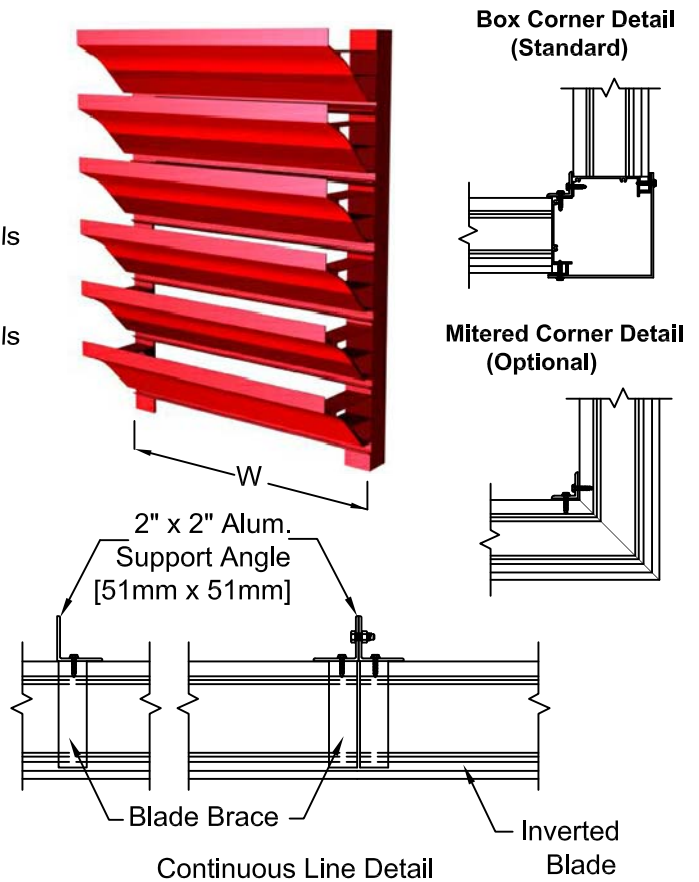
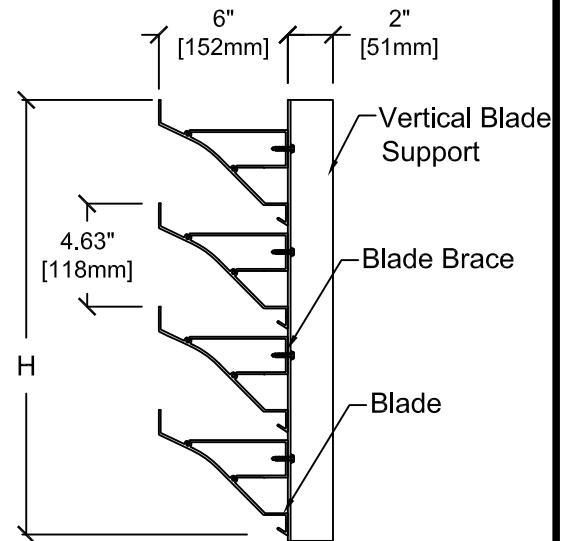

Due to continuing research, United Energetech reserves the right to change specifications without notice.



3005 South Hickory Street
Chattanooga, Tennessee 37407
Tel: (423) 698-7715
Fax: (423) 698-6629
www.unitedenergetech.com

MODEL ES-EL-6 (6" [152mm] Aluminum Equipment Screen)

DRAWN BY: MHM	DATE: 3-12-10	REV. DATE: 5-6-13	REV. NO. 1	APPROVED BY: BGT	DWG. NO.: A-51
------------------	------------------	----------------------	---------------	---------------------	-------------------

Model ES-EL-6 Typical Installation Details

