

**MODEL D-DR-4**

**DOUBLE DRAINABLE 4" FIXED LOUVER**

**STANDARD CONSTRUCTION:**

**Frame:** .081" Extruded Aluminum, 4.20" Deep

**Blade:** .094" Extruded Aluminum positioned on a 39° angle on approximately 4.25" centers

**Birdscreen:** .75" x .051" Flattened Aluminum in removable frame. Screen is mounted as standard on inside (rear) as looking from exterior of building.

**Finish:** Mill Aluminum (Std.)

**Minimum Size:** 9 x 9

**Maximum Single Section:** 84"w x 120"h or 120"w x 84"h

**Note:** Drainable blade louvers should be limited to 10' maximum section widths (no more than 10' between vertical downspouts) to enable the drainable design to function effectively.

**OPTIONS:**

- Flanged Frame (1.50" std.), (1" std for shapes R\_ )
- Custom Flange (1", 2" , or 3"), (1.5", 2", or 3" for shapes R\_ )
- Extended Sill
- Glazing Adapter (.50" or .75")
- Insect Screen (Other Screens Available, See Screen Page)
- Filter Racks (no screen)
- Security Bars
- Hinged Sub Frame
- Welded Construction (Wind Load +/- 50 psf)
- Blank-off, Alum., non-insulated, no screen, non-removeable
- Blank-off, Alum., non-insulated, with bird screen or insect screen
- Blank-off, Alum., insulated double wall, with bird screen, removable
- Blank-off, Alum., insulated double wall, no screen, non-removeable

**AVAILABLE FINISHES:**

- Powder Polyester TGIC** (2 coats) baked on at 410°F, 2.5 to 3.5 mils Meets AAMA-2603 Standards
- Powder Super durable polyester** (2 coats) baked on at 410°F, 2.5 to 3.5 mils Meets AAMA-2604-05 Standards
- Acrylic baked enamel** (ACRA-BOND® ULTRA) by AkzoNobel baked on at 350°F, 0.8 to 1.2 mils dry Meets AAMA-2603 Standards
- Kynar®** (ALUM\*A\*STAR®) 2 coats by AkzoNobel baked on at 450°F, 1.2 to 1.6 mils dry Meets AAMA-2604-05 Standards
- Kynar 500®** or **HYLAR® 5000 70% TRINAR®** (2 coats) by AkzoNobel baked on at 450°F, 1.2 to 1.6 mils dry, Meets AAMA-2605-05 Standards
- Kynar 500®** or **HYLAR® 5000 (70% Tri-Escent II)** (2 coats) by AkzoNobel, a superior finish to other metallic or anodized finishes. A blend of mica, ceramic, and inorganic pigments creates subtle yet dazzling design that goes beyond metallic color without the requirement of a clear coat. 14 standard colors - custom colors available. Baked on at 415°F, 1.4 to 1.8 mils dry, meets AAMA 2605-05.
- Clear Anodize 204 R-1 Class II** (AA-C22A31)(0.4 to 0.7 mil)
- Clear Anodize 215 R-1 Class I** (AA-C22A41)(>0.7 mil)
- Integral Color Anodize** (AA-C22A42)(>0.7 mil)
  - Clear coat available for all above finishes.
  - Hylar® 5000 is a registered trademark of Solvay Solexis, Inc.
  - Kynar® 500 is a registered trademark of Arkema.
  - ALUM\*A\*STAR® 50 and TRINAR® are registered trademarks of AkzoNobel
  - ACRA-BOND® ULTRA is a registered trademark of AkzoNobel

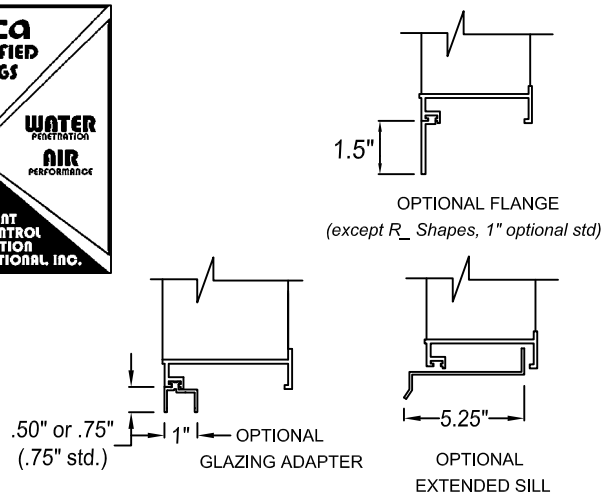
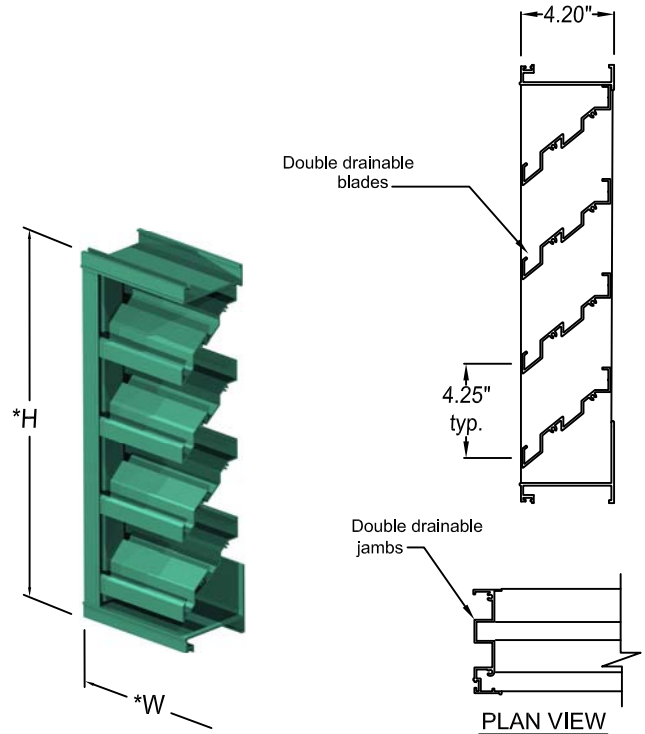

\*Width and Height dimensions are approximately 1/4" under listed size.

Due to continuing research, United Enertech reserves the right to change specifications without notice.

		3005 South Hickory Street Chattanooga, Tennessee 37407 Tel: (423) 698-7715 Fax: (423) 698-6629 <a href="http://www.unitedenertech.com">www.unitedenertech.com</a>			
		<b>MODEL D-DR-4 (Double Drainable 4" Deep Fixed Louver)</b>			
DRAWN BY: CLJ	DATE: December 2006	REV. DATE: April 2010	REV. NO. 1	APPROVED BY: BGT	DWG. NO.: <b>A-5</b>

# SUGGESTED SPECIFICATION

Furnish and install louvers as hereinafter specified where shown on plans or as described in schedules. Louvers shall be stationary dual drainable type with drain gutters in each blade and downspouts in jambs and mullions. Stationary drainable blades shall be contained within a 4.20" frame. Louver components (heads, jambs, sills, blades, and mullions) shall be factory assembled by the louver manufacturer. Louver sizes too large for shipping shall be built up by the contractor from factory assembled louver sections to provide overall sizes required. Louver design shall incorporate structural supports required to withstand a wind load of 30 lbs. Per sq. ft. (equivalent of a 110 mph wind)

Louvers shall be United Enertech #D-DR-4, 6063-T6 extruded aluminum construction as follows:

- Frame: 4.20" deep, .125 nominal wall thickness.
- Blades: .081 nominal wall thickness. Drainable.
- Blades are positioned at 39-degree angle and spaced approximately 4.25" center to center.
- Screen: .75" x .051" (19 x 1.3) expanded, flattened aluminum in removable frame.
- Finish: Select finish specification from United Enertech Finishes Brochure.

Publish louver performance data bearing the AMCA Certified Ratings Seal for Air Performance & Water Penetration must be submitted for approval prior to fabrication and must demonstrate pressure drop and water penetration equal to or less than the United Enertech model specified.

## PERFORMANCE DATA

### WATER PENETRATION

Standard Air-.075 lb/ft<sup>3</sup>

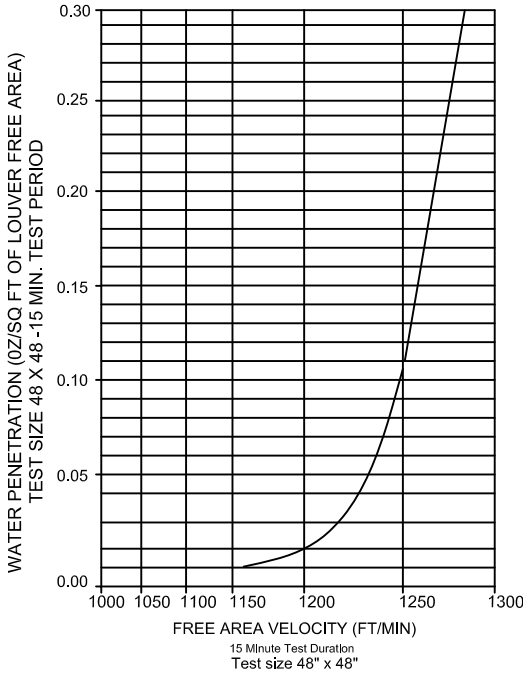

Beginning point of WATER PENETRATION  
is  
1157 fpm  
free area velocity at .01 oz. of water penetration

### AIR FLOW RESISTANCE

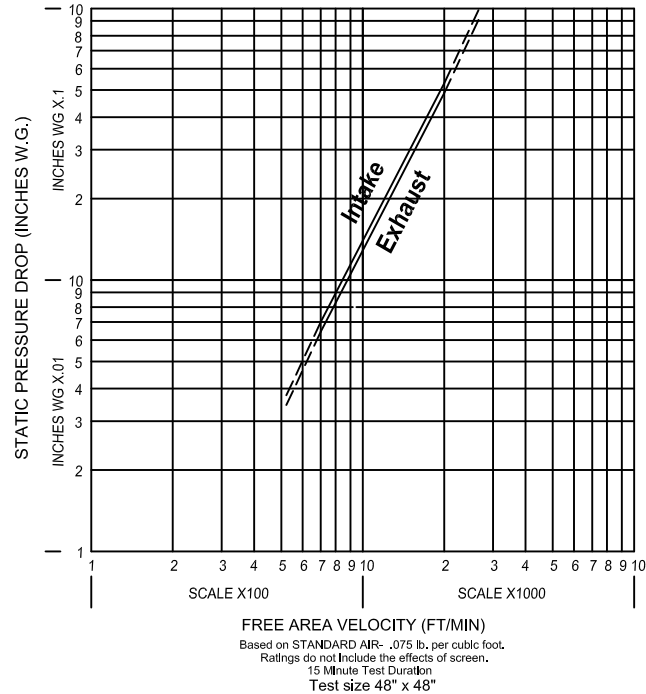

AMCA Standard 500-L provides a reasonable basis for testing and rating louvers. Testing to AMCA 500-L is performed under a certain set of laboratory conditions. This does not guarantee that other conditions will not occur in the actual environment where louvers must operate. The louver system should be designed with a reasonable safety factor for louver performance. To ensure protection from water carryover, design with a performance level somewhat below maximum desired pressure drop and .01 oz./sq. ft. of water penetration.

### MODEL D-DR-4 FREE AREA CHART (SQUARE FEET)

Louver Height Inches	Width - Inches																Louver Height Inches			
	12	18	24	30	36	42	48	54	60	66	72	78	84	90	96	102		108	114	120
12	0.28	0.45	0.63	0.80	0.97	1.15	1.32	1.49	1.67	1.84	2.01	2.18	2.36	2.53	2.70	2.88	3.05	3.22	3.40	12
18	0.44	0.71	0.97	1.24	1.51	1.78	2.05	2.32	2.59	2.86	3.13	3.39	3.66	3.93	4.20	4.47	4.74	5.01	5.28	18
24	0.56	0.91	1.25	1.60	1.94	2.28	2.63	2.97	3.32	3.66	4.01	4.35	4.70	5.04	5.39	5.73	6.08	6.42	6.77	24
30	0.85	1.37	1.89	2.41	2.93	3.45	3.98	4.50	5.02	5.54	6.06	6.58	7.11	7.63	8.15	8.67	9.19	9.71	10.23	30
36	1.00	1.62	2.24	2.86	3.47	4.09	4.71	5.33	5.94	6.56	7.18	7.80	8.41	9.03	9.65	10.27	10.88	11.50	12.12	36
42	1.32	2.14	2.95	3.76	4.58	5.39	6.20	7.02	7.83	8.64	9.46	10.27	11.08	11.90	12.71	13.52	14.34	15.15	15.96	42
48	1.48	2.39	3.30	4.21	5.12	6.03	6.94	7.85	8.76	9.67	10.58	11.49	12.40	13.31	14.21	15.12	16.03	16.94	17.85	48
54	1.61	2.59	3.58	4.57	5.56	6.54	7.53	8.52	9.51	10.50	11.48	12.47	13.46	14.45	15.43	16.42	17.41	18.40	19.39	54
60	1.89	3.05	4.21	5.37	6.54	7.70	8.86	10.02	11.18	12.35	13.51	14.67	15.83	17.00	18.16	19.32	20.48	21.64	22.81	60
66	1.90	3.06	4.23	5.40	6.57	7.73	8.90	10.07	11.24	12.40	13.57	14.74	15.91	17.07	18.24	19.41	20.58	21.74	22.91	66
72	2.19	3.53	4.88	6.22	7.57	8.92	10.26	11.61	12.95	14.30	15.64	16.99	18.34	19.68	21.03	22.37	23.72	25.06	26.41	72
78	2.35	3.79	5.24	6.68	8.12	9.57	11.01	12.46	13.90	15.35	16.79	18.24	19.68	21.12	22.57	24.01	25.46	26.90	28.35	78
84	2.65	4.28	5.91	7.54	9.17	10.80	12.44	14.07	15.70	17.33	18.96	20.59	22.22	23.85	25.48	27.11	28.74	30.38	32.01	84
90	2.82	4.56	6.30	8.03	9.77	11.51	13.24	14.98	16.72	18.46	20.19	21.93	23.67	25.40	27.14	28.88	30.61	32.35	34.09	90
96	2.94	4.75	6.56	8.37	10.18	11.99	13.80	15.61	17.42	19.23	21.04	22.85	24.67	26.48	28.29	30.10	31.91	33.72	35.53	96
102	3.23	5.22	7.21	9.20	11.19	13.18	15.16	17.15	19.14	21.13	23.12	25.11	27.10	29.09	31.07	33.06	35.05	37.04	39.03	102
108	3.39	5.47	7.55	9.64	11.72	13.80	15.89	17.97	20.05	22.14	24.22	26.31	28.39	30.47	32.56	34.64	36.72	38.81	40.89	108
114	3.50	5.65	7.80	9.95	12.10	14.25	16.41	18.56	20.71	22.86	25.01	27.16	29.32	31.47	33.62	35.77	37.92	40.07	42.23	114
120	3.67	5.93	8.19	10.45	12.71	14.97	17.23	19.49	21.75	24.00	26.26	28.52	30.78	33.04	35.30	37.56	39.82	42.08	44.34	120



United Enertech certifies that the D-DR-4 shown herein is licensed to bear the AMCA Seal. The ratings shown are based on tests and procedures performed in accordance with AMCA Publication 511 and comply with the requirements of the AMCA Certified Ratings Program. The AMCA Seal applies to air performance ratings and water penetration ratings.