

JACKSHAFTING DETAILS

Select: 1 thru 13

Jackshaft Configurations

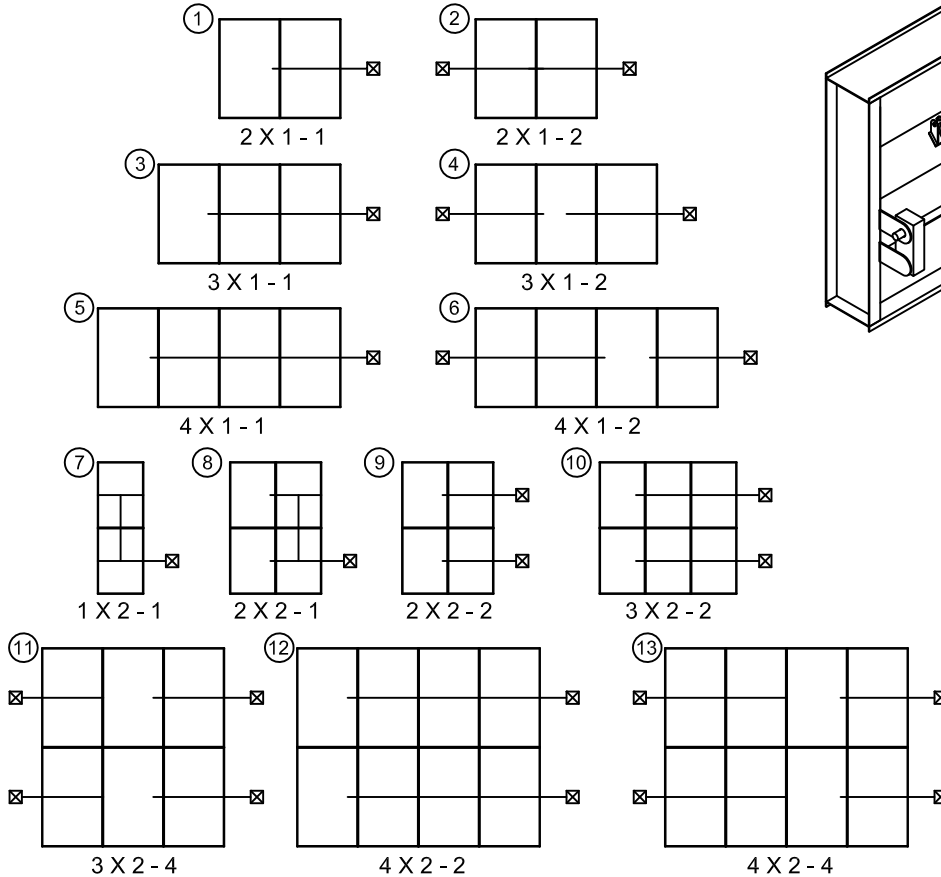

CONFIGURATION LEGEND:



OPTIONAL:

- Actuator in Airstream
- Actuator out of Airstream

1. The primary function of a Jackshaft is to distribute power equally to each section of a multiple section damper. This is best achieved by linking the operator directly to the Jackshaft which in turn will control all of the individual sections as one.
2. Dampers are undersized approximately $\frac{1}{4}$ " for both width and height on entire multi-section assembly.
3. Dampers are self-supporting only in the largest recommended single section. Additional bracing at every 8 feet of damper width and height is recommended on multiple section assemblies.
4. During field installation of damper sections, it is important that final linkage positions are set so that all sections open and close simultaneously for their given operator.
5. Jackshafting will be located near the bottom of damper section height.
6. If actuators are field mounted, actuator must be powered up and then locked down on shaft.

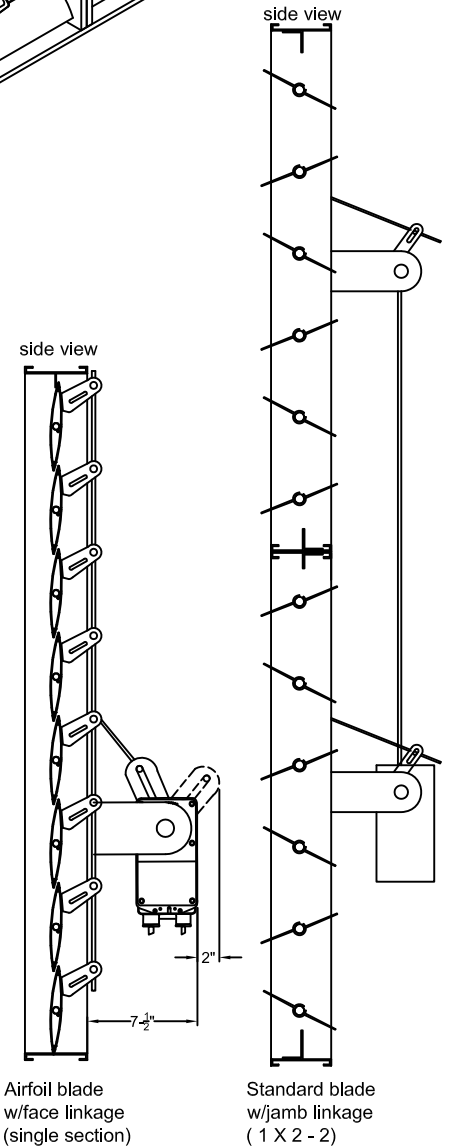
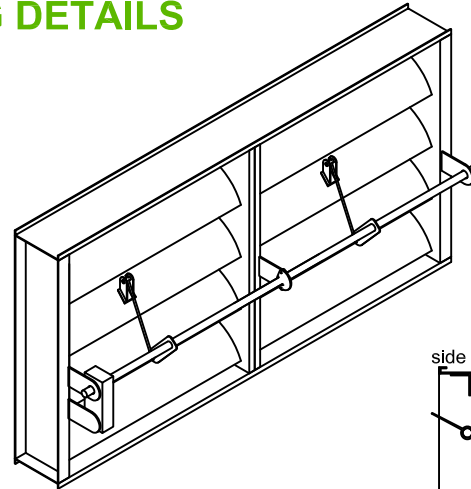

Job Name:	<input type="checkbox"/> <b style="color: green;">JACKSHAFTING DETAILS		
Location:	DRAWN BY: SRB	DATE: 5-16-07	REV. DATE: 9-30-10
Architect:	REV. NO. 4	APPROVED BY: BGT	DWG. NO.: A-27
Engineer:			
Contractor:			