



5" Deep Wind Driven Rain / Hurricane Louver

Miami-Dade Approved

Miami-Dade County, Florida Notice of Acceptance #: 09-0922-11 (Expires 11-20-2013)

Florida Building Code product approval # FL11731

APPLICATION AND FEATURES

The Model **DCSED-5.1** is a sight proof, drainable, wind-driven rain louver which incorporates a series of (11) vertical and (5) horizontal drains designed to protect the outside opening in building exterior walls. It is engineered for use in Dade County, FL and its municipalities as well as other regions that use Dade County codes. These louvers may be used for exhaust or intake air. Engineers can design with confidence as this product complies with the Miami-Dade County Building Code.

STANDARD CONSTRUCTION:

FRAME:

.081 Extruded Aluminum 5" Deep

BLADES:

.081 Extruded Aluminum on approximately 2" centers.

BIRDSCREEN:

3/4" x .051" Flattened Aluminum in removeable frame.
 Screen is mounted as standard on inside (rear) as looking from exterior of building.

FINISH:

Mill Aluminum (Standard)

MINIMUM SIZE:

12"w x 12"h

Maximum Design Pressure Rating
 +150.0, -150.0 psf
 Large Missile Impact Resistance

*Product approval in accordance with
 2007 edition Florida Building Code.*

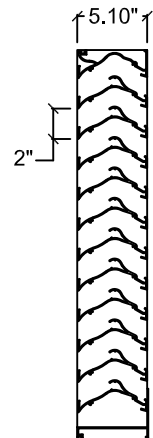

NOTE: Please specify the following for proper construction of mounting hardware.
 Wall Thickness _____"
 Design Wind Load _____
 Substrate _____
 (Concrete or Steel)

MAXIMUM SIZE LIMITATIONS

+/-60 psf maximum design pressure		+/-150 psf maximum design pressure	
single section	multi-section	single section	multi-section
72" w X 120"h	unlimited width X 120"h	72" w X 84"h	unlimited width X 84"h

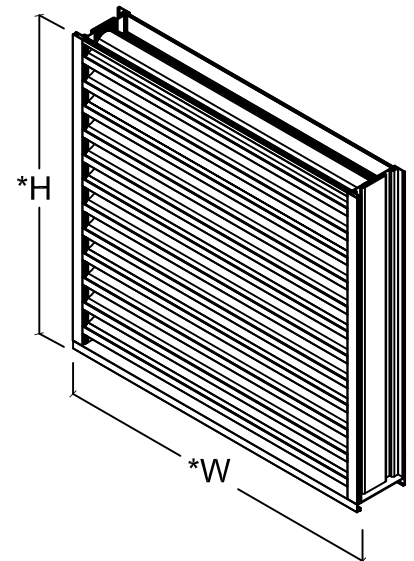

OPTIONS:

- Flanged Frame
- Custom Flange
- Insect Screen
Aluminum 18-16 Mesh Mill
.011" (.3) Wire Diameter
- Filter Racks
- Security Bars
- Rear mounted CD-150 damper

FINISH:

- Clear Anodize
- Integral Color Anodize
- Baked Powder Polyester
- Baked Powder Fluoropolymer 70%
- Baked Powder Clear Coat

*W & H dimensions furnished approximately 1/4" under size.

Job Name:	<input type="checkbox"/> MODEL DCSED-5.1		
Location:			
Architect:	DRAWN BY: CLJ	DATE: October 2008	REV. DATE: April 2009
Engineer:	REV. NO. 4	APPROVED BY:	DWG. NO.: E-9d
Contractor:			

Model DCSED-5.1 Louver Performance Data

SED-5.1 FREE AREA IN SQ. FT.

Louver Height Inches	Width - Inches																Louver Height Inches			
	12	18	24	30	36	42	48	54	60	66	72	78	84	90	96	102		108	114	120
12	0.31	0.51	0.70	0.90	1.10	1.29	1.49	1.69	1.88	2.08	2.28	2.47	2.67	2.87	3.06	3.26	3.46	3.65	3.85	12
18	0.49	0.80	1.10	1.41	1.72	2.03	2.33	2.64	2.95	3.26	3.57	3.87	4.18	4.49	4.80	5.10	5.41	5.72	6.03	18
24	0.69	1.12	1.56	1.99	2.43	2.86	3.30	3.73	4.17	4.60	5.04	5.47	5.90	6.34	6.77	7.21	7.64	8.08	8.51	24
30	0.99	1.61	2.24	2.86	3.48	4.11	4.73	5.36	5.98	6.60	7.23	7.85	8.48	9.10	9.72	10.35	10.97	11.60	12.22	30
36	1.16	1.90	2.63	3.37	4.11	4.84	5.58	6.31	7.05	7.78	8.52	9.25	9.99	10.72	11.46	12.19	12.93	13.66	14.40	36
42	1.44	2.35	3.26	4.17	5.08	5.98	6.89	7.80	8.71	9.62	10.53	11.44	12.35	13.26	14.17	15.08	15.98	16.89	17.80	42
48	1.62	2.64	3.66	4.68	5.70	6.72	7.74	8.76	9.78	10.80	11.82	12.84	13.86	14.88	15.90	16.92	17.94	18.96	19.98	48
54	1.82	2.96	4.11	5.26	6.41	7.55	8.70	9.85	10.99	12.14	13.29	14.44	15.58	16.73	17.88	19.02	20.17	21.32	22.47	54
60	2.12	3.45	4.79	6.13	7.46	8.80	10.14	11.47	12.81	14.15	15.48	16.82	18.15	19.49	20.83	22.16	23.50	24.84	26.17	60
66	2.29	3.74	5.19	6.64	8.08	9.53	10.98	12.43	13.87	15.32	16.77	18.22	19.67	21.11	22.56	24.01	25.46	26.91	28.35	66
72	2.49	4.07	5.64	7.22	8.79	10.37	11.94	13.52	15.09	16.67	18.24	19.81	21.39	22.96	24.54	26.11	27.69	29.26	30.84	72
78	2.79	4.56	6.32	8.09	9.85	11.61	13.38	15.14	16.91	18.67	20.43	22.20	23.96	25.73	27.49	29.25	31.02	32.78	34.55	78
84	2.97	4.84	6.72	8.60	10.47	12.35	14.22	16.10	17.97	19.85	21.72	23.60	25.47	27.35	29.22	31.10	32.97	34.85	36.72	84
90	3.17	5.17	7.17	9.18	11.18	13.18	15.18	17.19	19.19	21.19	23.19	25.19	27.20	29.20	31.20	33.20	35.21	37.21	39.21	90
96	3.47	5.66	7.85	10.04	12.24	14.43	16.62	18.81	21.00	23.19	25.39	27.58	29.77	31.96	34.15	36.34	38.53	40.73	42.92	96
102	3.65	5.95	8.25	10.55	12.86	15.16	17.46	19.77	22.07	24.37	26.67	28.98	31.28	33.58	35.89	38.19	40.49	42.79	45.10	102
108	3.85	6.28	8.71	11.14	13.57	16.00	18.43	20.85	23.28	25.71	28.14	30.57	33.00	35.43	37.86	40.29	42.72	45.15	47.58	108
114	4.15	6.77	9.38	12.00	14.62	17.24	19.86	22.48	25.10	27.72	30.34	32.96	35.58	38.19	40.81	43.43	46.05	48.67	51.29	114
120	4.32	7.05	9.78	12.51	15.24	17.97	20.70	23.44	26.17	28.90	31.63	34.36	37.09	39.82	42.55	45.28	48.01	50.74	53.47	120

The Beginning point of WATER PENETRATION lies above **1250 FPM** free area velocity at .01 oz. of water penetration

TAS 100(A)-95 WIND DRIVEN RAIN RESISTANCE TEST (LOUVER WITH OPTIONAL CD-151)

WIND VELOCITY MPH (KPH)	RAIN FALL RATE IN./HR. (MM/HR.)	ALLOWABLE PENETRATION OZ (ML)	ACTUAL PENETRATION OZ (ML)
35 (56)	8.8 (224)	0	0
70 (113)	8.8 (224)	0	0
90 (145)	8.8 (224)	1.44 (42.6)	0
110 (177)	8.8 (224)	0.48 (14.2)	0

WIND DRIVEN RAIN

Wind Velocity (mph)	Class
29	3
50	3

* Discharge loss coefficient is the theoretical air flow of an opening divided by the actual flow rate of a louver the same size.

Class	Discharge Loss Coefficient
1	0.4 and above
2	0.3 to 0.399
3	0.2 to 0.299
4	.0199 and below

(the higher the coefficient, the less resistance to airflow.)

Class	Effectiveness
A	1 to 0.99
B	0.989 to 0.95
C	0.949 to 0.80
D	Below 0.8

Ventilation Air Core Velocity m/s (fpm)	200 mm/h (8in/h) Rainfall & 32 m/s (50 mph) Wind Velocity	
	Water Penetration Effectiveness %	*Water Penetration Classification
0.0 (0)	98.3	B
0.49 (96)	98.0	B
1.10 (217)	97.0	B
1.47 (289)	97.0	B
1.92 (378)	96.3	B
2.53 (499)	95.3	B
2.89 (570)	94.2	C
3.43 (676)	88.9	C
3.89 (766)	85.2	C

*AMCA Classes for maximum allowable water penetrations

Test size 1m x 1m(39"x39")core
41½" w x 41" h Nominal(1.05m x 1.04m)

AIR FLOW RESISTANCE

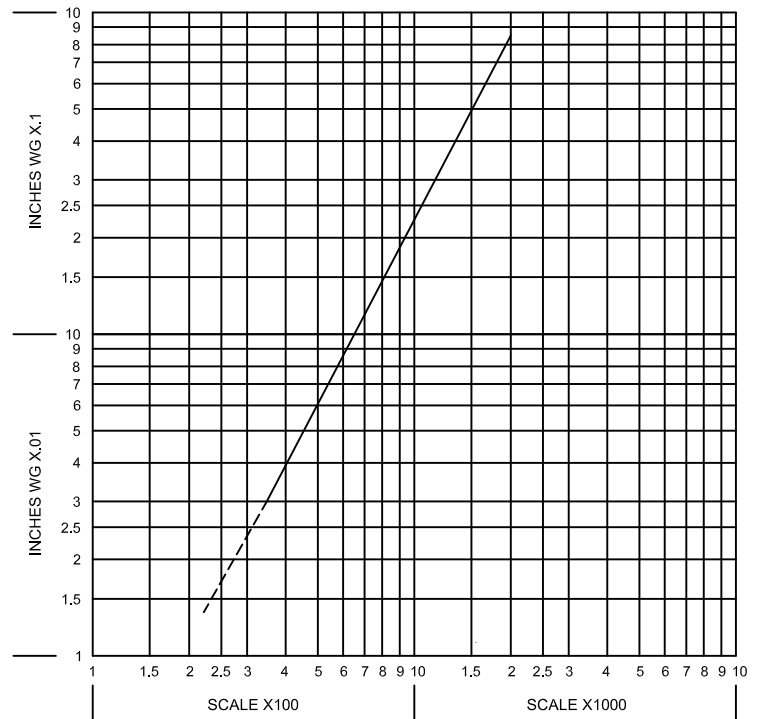

PRESSURE DROP INTAKE & EXHAUST

FREE AREA VELOCITY (FT/MIN)
Based on STANDARD AIR- .075 lb. per cubic foot.
Ratings do not include the effects of screen.

SIZE TESTED: 48" X 48"

Model DCSED-5.1 Single Unit Installation

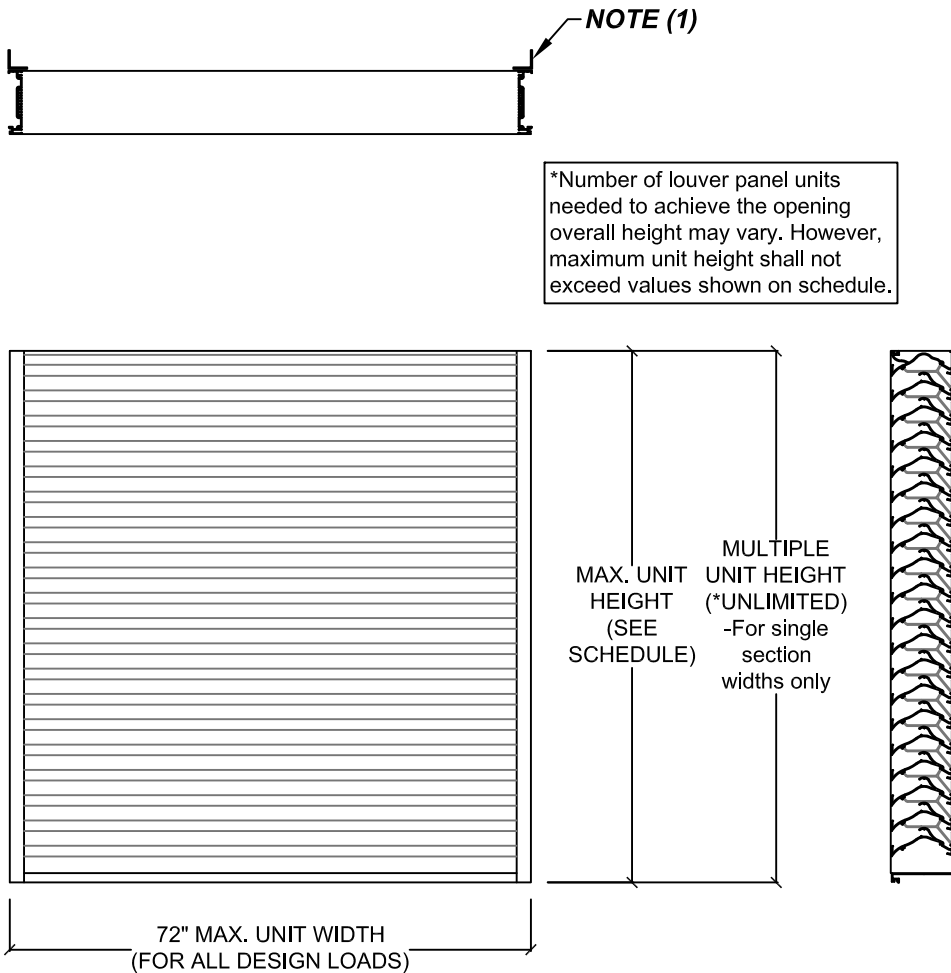

DESIGN WIND LOAD (PSF)	MAX. UNIT HEIGHT
40	120"
45	120"
50	120"
55	120"
60	120"
65	120"
70	120"
75	119"
80	115"
85	112"
90	108"
95	106"
100	103"
105	100"
110	98"
115	96"
120	94"
125	92"
130	90"
135	89"
140	87"
145	85"
150	84"

Notes:

(1) 1½" x 1½" x .125" alum. continuous vertical angle attached to louver jambs with ¼"Ø x ¾" long tek screws, 8" o.c., and attached to substrate as listed in the table below.

ANCHOR SPACING SCHEDULE AT JAMBS WITH (1½" X 1½" X .125" ALUM. ANGLE)				
DESIGN WIND LOAD (PSF)	SINGLE UNIT WIDTH	MAXIMUM FASTENER SPACING (in.)		
		¼"Ø X 2" LONG TAPCONS TO CONCRETE	¼"Ø X 2" LONG TAPCONS TO CMU BLOCK	¼"Ø X 1" LONG TEK SCREWS TO STEEL
75 OR LESS	48	8" o.c.	7-1/2" o.c.	8" o.c.
	60	8" o.c.	6" o.c.	8" o.c.
	72	8" o.c.	5" o.c.	8" o.c.
> 75 TO 110	48	8" o.c.	5" o.c.	8" o.c.
	60	8" o.c.	4" o.c.	8" o.c.
	72	7" o.c.	3" o.c.	7 1/2" o.c.
> 110 TO 150	48	8" o.c.	3-1/2" o.c.	8" o.c.
	60	6-1/2" o.c.	3" o.c.	6-1/2" o.c.
	72	5" o.c.	N/A	5-1/2" o.c.

FOR MULTIPLE SECTION WIDTHS, PLEASE CONSULT FACTORY. MORE INFORMATION AVAILABLE ON NOA DRAWINGS. (APPROVAL NO. 08-1003.07)