

Drainable Blade w/ Jamb Gutters Downspouts

HIGH PERFORMANCE COMBINATION LOUVER/DAMPER 4"

APPLICATION AND FEATURES:

The Model CEL-D-4 is a weather louver combination damper designed to protect the outside opening in building exterior walls. These louvers may be used for exhaust or intake air. This model incorporated drainable blade and downspouts jamb gutter design for high performance.

STANDARD CONSTRUCTION

FRAME:

.081" Extruded Aluminum 4.125" deep.

ADJUSTABLE BLADE:

.061" Extruded Aluminum

FIXED BLADE:

.081 Extruded Aluminum Positioned on a 39° angle on approximately 4.25" centers.

LINKAGE:

Exposed (In-air-stream)

BIRDSCREEN:

3/4" X .051 Flattened Aluminum in Removable Frame. Screen is mounted on inside (rear) as looking from exterior of building.

FINISH:

Mill aluminum (std.)

MINIMUM SIZE:

12"w x 12"h

MAXIMUM SIZE:

Factory assembled multi-section max: 84"w x 120"h
 60"w x 120"h single section
 Larger sizes are field assembled.

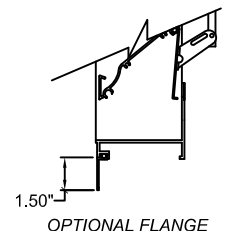
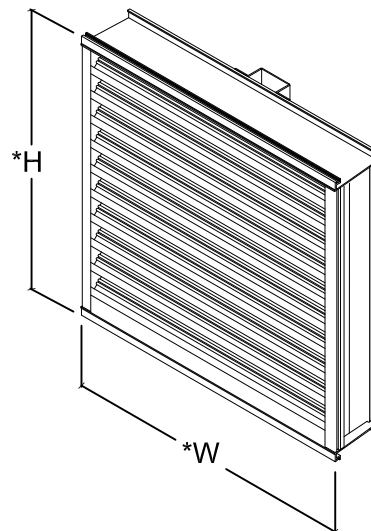
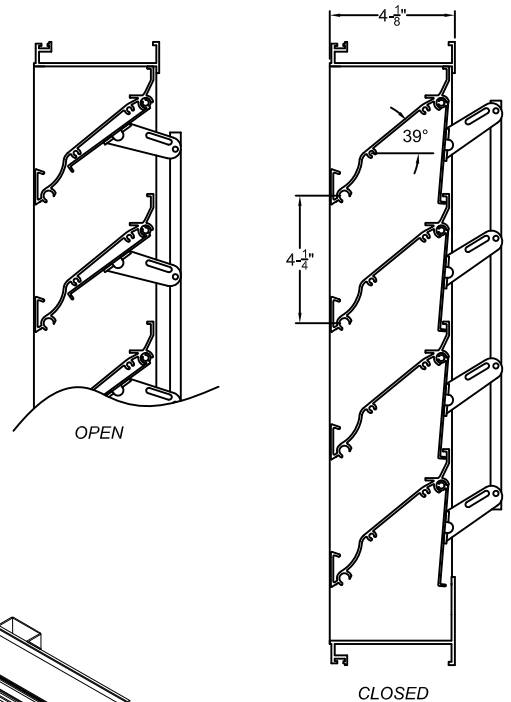

OPTIONS: (at additional cost)

- Flanged Frame (1-1/2" std.)
- Custom Flanges (1", 2", or 3")
- Glazing Adapter (1/2" or 3/4")
- Extended Sill
- Insect Screen (Aluminum 18-16 Mesh)
- Blade Seals
- Filter Racks
- Security Bars
- Hinged Subframe

FINISHES:

- Baked Powder Polyester
- Baked Powder Fluoropolymer 70%
- Baked Powder Clear Coat
- Clear Anodize
- Integral Color Anodize

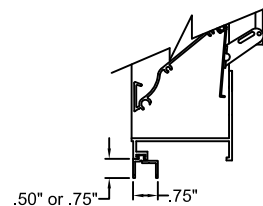

OPTIONAL GLAZING ADAPTER



OPTIONAL EXTENDED SILL

*W & H dimensions furnished approximately 1/4" under size.

Job Name:	<input type="checkbox"/> MODEL CEL-D-4		
Location:			
Architect:	DRAWN BY:	DATE:	REV. DATE:
Engineer:	SRB	June 2009	August 2009
Contractor:	REV. NO.	APPROVED BY:	DWG. NO.:
	3	SDC	E-5a

Louver Selection and Application

CEL-D-4 FREE AREA IN SQ. FT.

Height - Inches	Width - Inches									Louver Height Inches
	12	18	24	30	36	42	48	54	60	
12	0.24	0.39	0.55	0.70	0.85	1.00	1.15	1.30	1.45	12
18	0.47	0.75	1.04	1.32	1.61	1.90	2.18	2.47	2.76	18
24	0.66	1.06	1.47	1.88	2.28	2.69	3.09	3.50	3.90	24
30	0.93	1.51	2.08	2.65	3.23	3.80	4.38	4.95	5.52	30
36	1.09	1.76	2.43	3.09	3.76	4.43	5.10	5.77	6.44	36
42	1.35	2.18	3.00	3.83	4.66	5.49	6.32	7.15	7.98	42
48	1.55	2.51	3.47	4.42	5.38	6.34	7.29	8.25	9.21	48
54	1.76	2.84	3.93	5.01	6.10	7.18	8.26	9.35	10.43	54
60	2.02	3.26	4.50	5.74	6.98	8.22	9.46	10.70	11.94	60
66	2.02	3.26	4.50	5.74	6.98	8.22	9.46	10.70	11.94	66
72	2.45	3.96	5.46	6.97	8.48	9.98	11.49	13.00	14.51	72
78	2.61	4.22	5.82	7.43	9.04	10.64	12.25	13.86	15.46	78
84	2.86	4.63	6.39	8.15	9.91	11.67	13.44	15.20	16.96	84
90	3.10	5.01	6.92	8.83	10.73	12.64	14.55	16.46	18.37	90
96	3.28	5.29	7.31	9.33	11.35	13.36	15.38	17.40	19.41	96
102	3.55	5.74	7.92	10.11	12.29	14.48	16.66	18.85	21.04	102
108	3.72	6.01	8.30	10.59	12.88	15.17	17.46	19.75	22.04	108
114	3.97	6.41	8.85	11.29	13.73	16.17	18.61	21.05	23.49	114
120	4.19	6.76	9.34	11.92	14.49	17.07	19.64	22.22	24.80	120

CEL-D-4 Selection and Examples

Example 1:

Airflow given as 10,000 cfm - select louver size

A. Determine louver free area by dividing airflow by free area velocity (do not exceed 1100 fpm on intake louver application).

$$10,000 \text{ cfm} / 1100 \text{ fpm} = 9.09 \text{ sq.ft.}$$

$$\text{Airflow} / \text{Velocity} = \text{Free Area}$$

B. Select a louver size with at least the required free area from the chart above (9.09 sq.ft.).

60" wide x 48" high CFL-D-4.1 louver = 9.21 sq.ft.
(other selections available, see chart above)

C. Check the pressure drop of the selected louver at the selected louver given airflow (Airflow Resistance Chart on page 2).

$$\Delta P \text{ at } 1100 \text{ fpm} = 0.XX \text{ in. w.g.}$$

velocity pressure drop

Example 2:

Louver size given as 36" wide x 36" high.
Determine maximum airflow.

A. Use Free Area Chart to determine

$$\text{Free Area} = 3.76 \text{ sq.ft.}$$

B. Multiply Free Area by Free Area Velocity (Do not exceed 1100 fpm on intake louver applications).

$$3.76 \text{ sq.ft.} \times 1100 \text{ fpm} = \underline{4,136 \text{ cfm}}$$

$$\text{Free Area} \times \text{Max. Airflow Velocity} = \text{Max. Airflow}$$

C. Check the pressure drop of the selected louver at the given airflow (Airflow Resistance Chart on page 2).

$$\Delta P \text{ at } 1100 \text{ fpm (max)} = 0.XX \text{ in. w.g.}$$

velocity pressure drop

SUGGESTED SPECIFICATION

Finish and install louvers as hereinafter specified where shown on plans or as described in schedules. Louvers shall be drainable blade style with 39° stationary blades. Stationary blades shall be contained within a 4¹/₈" frame. Louver components (heads, jambs, sills, blades, and mullions) shall be factory assembled by the louver manufacturer. Louver sizes too large for shipping shall be built up by the contractor from factory assembled louver sections to provide overall sizes required. Louver design shall incorporate structural supports required to withstand a wind load of 25 lbs. per sq. ft. (equivalent of a 100 mph wind).

Louvers shall be United Enertech CEL-D-4 6063T5 aluminum construction as follows:

FRAME: 4¹/₈" deep, .081" nominal wall thickness

BLADES: .081" nominal wall thickness (fixed) and .061" wall thickness (moveable). Blades are positioned at 39° angle and spaced approximately 4.25" center to center.

SCREEN: 3/4" x .051" (19 x 1.3) expanded, flattened aluminum in removable frame.

FINISH: Select finish specification from United Enertech Finishes brochure.

Published louver performance data bearing the AMCA Certified Ratings seal for Air Performance & Water Penetration must be submitted for approval prior to fabrication and must demonstrate pressure drop and water penetration equal to or less than the United Enertech model specified.

PERFORMANCE DATA

AMCA Standard 500 provides a reasonable basis for testing and rating louvers. Testing to AMCA 500 is performed under a certain set of laboratory conditions. This does not guarantee that other conditions will not occur in the actual environment where louvers must operate. The louver system should be designed with a reasonable safety factor for louver performance. To ensure protection from water carryover, design with a performance level somewhat below maximum desired pressure drop and .01 oz./sq. ft. of water penetration.

Beginning point of **WATER PENETRATION**
for **MODEL CEL-D-4** is
1058 fpm
free area velocity at .01 oz. of water
(penetration)



United Enertech Corporation certifies that the louver model shown hereon is licensed to bear the AMCA seal. The ratings shown are based on tests and procedures performed in accordance with the AMCA publication 511 and comply with the requirement of the AMCA Certified Ratings Program. The AMCA Certified Ratings Seal applies to Air Performance and Water Penetration ratings.

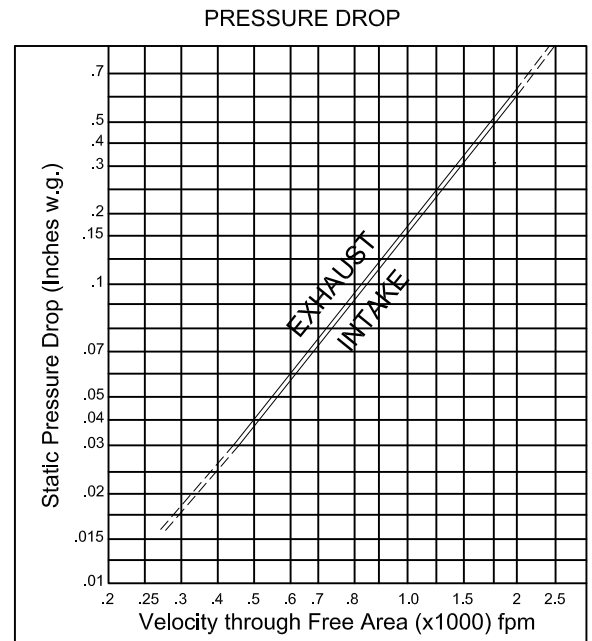
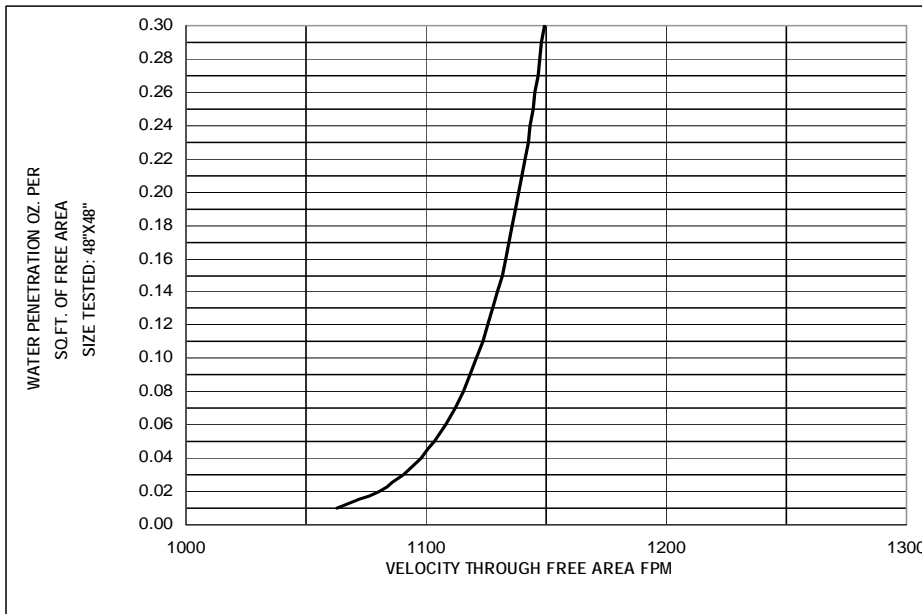

TEST SIZE: 48" X 48"

Based on STANDARD AIR - .075 lb. per cubic ft.
Ratings do not include the effects of the screen.