

Drainable Blade w/ Jamb Gutters Downspouts

HIGH PERFORMANCE COMBINATION LOUVER/DAMPER 6"

APPLICATION AND FEATURES:

The Model CFL-D-6 is a weather louver combination damper designed to protect the outside opening in building exterior walls. These louvers may be used for exhaust or intake air. This model incorporated drainable blade and downspouts jamb gutter design for high performance. Engineers and designers can design with confidence since this product is licensed to bear the AMCA Water and Air Seal.

STANDARD CONSTRUCTION

FRAME:

.125 Extruded Aluminum 6.20" deep.

ADJUSTABLE BLADE:

.125 Extruded Aluminum

FIXED BLADE:

.081 Extruded Aluminum Positioned on a 37° angle on approximately 3.58" centers.

LINKAGE:

Exposed

BIRDSCREEN:

3/4" X .051 Flattened Aluminum in Removable Frame. Screen is mounted on inside (rear) as looking from exterior of building.

FINISH:

Mill aluminum (std.)

MINIMUM SIZE:

12"w x 12"h

MAXIMUM SIZE:

Factory assembled multi-section max: 108"w x 120"h
 60"w x 120"h single section
 Larger sizes are field assembled.

Note: Drainable blade louvers should be limited to 10' maximum section width (no more than 10' between vertical downspouts) to enable the drainable design to function effectively.

OPTIONS: (at additional cost)

- Flanged Frame (1-1/2" std.)
- Custom Flange (1", 2", or 3")
- Glazing Adapter (1/2" or 3/4")
- Extended Sill
- Insect Screen (Aluminum 18-16 Mesh)
- Blade Seals
- Jamb Seals
- Filter Racks
- Security Bars
- Hinged Subframe

FINISHES:

- Baked Powder Polyester
- Baked Powder Fluoropolymer 70%
- Baked Powder Clear Coat
- Clear Anodize
- Integral Color Anodize

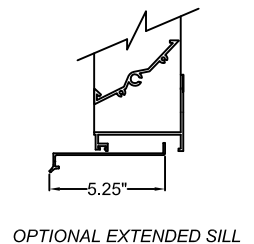
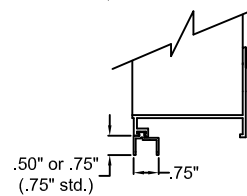
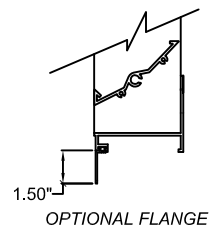
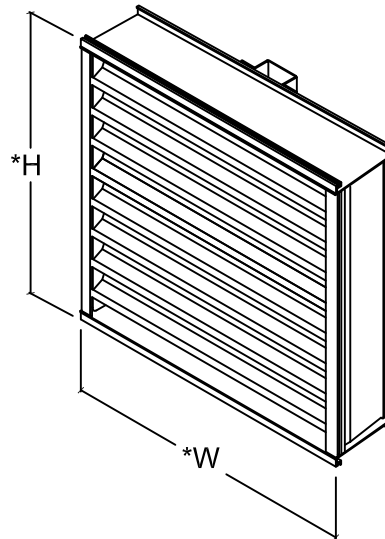
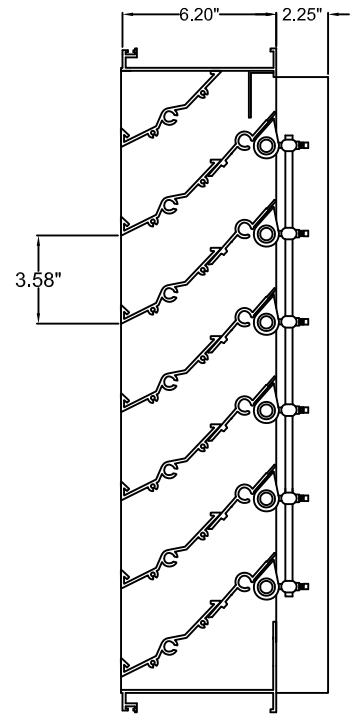

*W & H dimensions furnished approximately 1/4" under size.

Job Name:	<input type="checkbox"/> MODEL CFL-D-6		
Location:			
Architect:	DRAWN BY:	DATE:	REV. DATE:
Engineer:	CLJ	April 2000	January 2009
Contractor:	REV. NO.	APPROVED BY:	DWG. NO.:
	4	BGT	E-5

SUGGESTED SPECIFICATION

Finish and install louvers as hereinafter specified where shown on plans or as described in schedules. Louvers shall be combination louver/dampers drainable type with drain gutters in each blade and downspouts in jambs and mullions. Stationary drainable blades shall be contained within a 6.20" frame. Louver components (heads, jambs, sills, blades, and mullions) shall be factory assembled by the louver manufacturer. Louver sizes too large for shipping shall be built up by the contractor from factory assembled louver sections to provided overall sizes required. Louver design shall incorporate structural supports required to withstand a wind load of 25 lbs. per sq. ft. (equivalent of a 100 mph wind).

Louvers shall be United Enertech CFL-D-6 6063T5 aluminum construction as follows:

FRAME: 6.20" deep, .125" nominal wall thickness

ADJUSTABLE BLADES: .125" extruded aluminum

FIXED BLADES: .081" nominal wall thickness. Blades are positioned at 37° angle and spaced approximately 3.58" center to center.

SCREEN: $\frac{3}{4}$ " x .051" (19 x 1.3) expanded, flattened aluminum in removable frame.

FINISH: Select finish specification from United Enertech Finishes brochure.

Published louver performance data bearing the AMCA Certified Ratings seal for Air Performance & Water Penetration must be submitted for approval prior to fabrication and must demonstrate pressure drop and water penetration equal to or less than the United Enertech model specified.

PERFORMANCE DATA

AMCA Standard 500 provides a reasonable basis for testing and rating louvers. Testing to AMCA 500 is performed under a certain set of laboratory conditions. This does not guarantee that other conditions will not occur in the actual environment where louvers must operate. The louver system should be designed with a reasonable safety factor for louver performance. To ensure protection from water carryover, design with a performance level somewhat below maximum desired pressure drop and .01 oz./sq. ft. of water penetration.

Beginning point of **WATER PENETRATION**
for **MODEL CFL-D-6** is
1158 fpm
free area velocity at .01 oz. of water
(penetration)



United Enertech Corporation certifies that the louver model shown hereon is licensed to bear the AMCA seal. The ratings shown are based on tests and procedures performed in accordance with the AMCA publication 511 and comply with the requirement of the AMCA Certified Ratings Program. The AMCA Certified Ratings Seal applies to Air Performance and Water Penetration ratings.

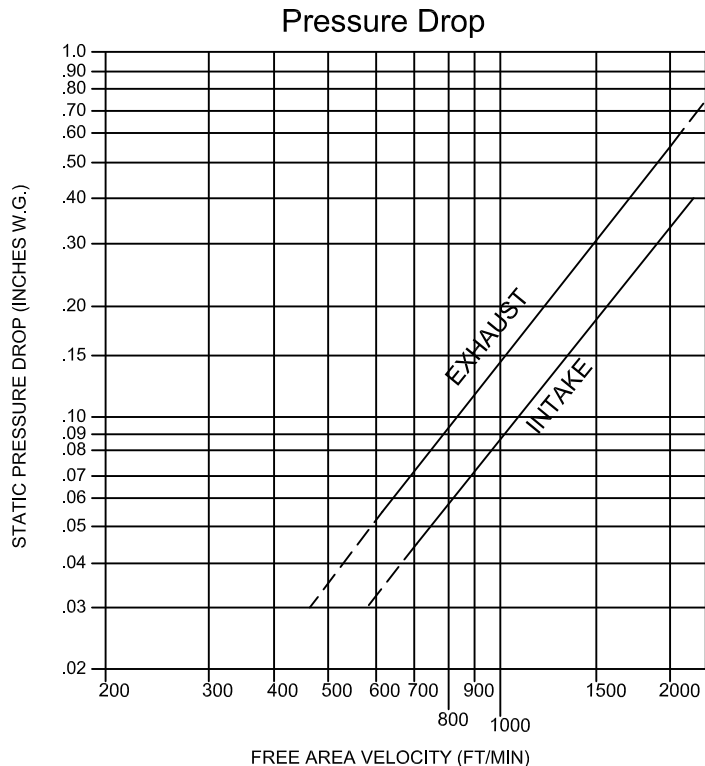
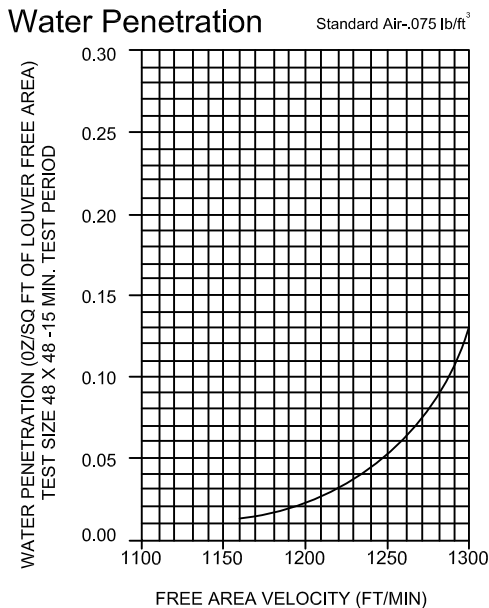

Based on STANDARD AIR- .075 lb. per cubic foot.
Ratings do not include the effects of screen.

Louver Selection and Application

FREE AREA CHART (SQUARE FEET)

Louver Height Inches	Louver Width In Inches																		Louver Height Inches	
	12	18	24	30	36	42	48	54	60	66	72	78	84	90	96	102	108	114		120
12	0.19	0.30	0.42	0.54	0.65	0.77	0.89	1.01	1.12	1.24	1.36	1.47	1.59	1.71	1.82	1.94	2.06	2.18	2.29	12
18	0.41	0.67	0.93	1.19	1.45	1.72	1.98	2.24	2.50	2.76	3.02	3.28	3.54	3.80	4.06	4.32	4.58	4.84	5.10	18
24	0.68	1.11	1.54	1.97	2.40	2.83	3.26	3.69	4.12	4.55	4.98	5.41	5.84	6.27	6.70	7.13	7.56	7.99	8.42	24
30	0.88	1.43	1.99	2.54	3.09	3.65	4.20	4.75	5.31	5.86	6.41	6.97	7.52	8.07	8.63	9.18	9.73	10.29	10.84	30
36	1.09	1.78	2.46	3.15	3.83	4.52	5.21	5.89	6.58	7.26	7.95	8.63	9.32	10.01	10.69	11.38	12.06	12.75	13.43	36
42	1.36	2.22	3.08	3.93	4.79	5.65	6.50	7.36	8.22	9.07	9.93	10.79	11.64	12.50	13.36	14.21	15.07	15.93	16.78	42
48	1.56	2.54	3.52	4.50	5.48	6.46	7.44	8.42	9.40	10.38	11.35	12.33	13.31	14.29	15.27	16.25	17.23	18.21	19.19	48
54	1.75	2.86	3.96	5.06	6.17	7.27	8.37	9.47	10.58	11.68	12.78	13.89	14.99	16.09	17.19	18.30	19.40	20.50	21.61	54
60	2.04	3.33	4.61	5.89	7.18	8.46	9.74	11.02	12.31	13.59	14.87	16.16	17.44	18.72	20.01	21.29	22.57	23.86	25.14	60
66	2.24	3.64	5.05	6.45	7.86	9.27	10.67	12.08	13.48	14.89	16.30	17.70	19.11	20.51	21.92	23.32	24.73	26.14	27.54	66
72	2.39	3.90	5.40	6.90	8.41	9.91	11.42	12.92	14.42	15.93	17.43	18.93	20.44	21.94	23.45	24.95	26.45	27.96	29.46	72
78	2.72	4.43	6.14	7.85	9.56	11.27	12.98	14.69	16.40	18.11	19.82	21.53	23.24	24.95	26.65	28.36	30.07	31.78	33.49	78
84	2.91	4.74	6.57	8.40	10.23	12.06	13.90	15.73	17.56	19.39	21.22	23.05	24.88	26.71	28.54	30.37	32.20	34.03	35.86	84
90	3.12	5.08	7.04	9.00	10.97	12.93	14.89	16.85	18.81	20.77	22.73	24.69	26.66	28.62	30.58	32.54	34.50	36.46	38.42	90
96	3.40	5.54	7.67	9.81	11.95	14.08	16.22	18.36	20.49	22.63	24.77	26.90	29.04	31.18	33.31	35.45	37.59	39.72	41.86	96
102	3.59	5.85	8.11	10.36	12.62	14.88	17.13	19.39	21.65	23.91	26.16	28.42	30.68	32.93	35.19	37.45	39.71	41.96	44.22	102
108	3.80	6.18	8.57	10.96	13.34	15.73	18.12	20.50	22.89	25.28	27.66	30.05	32.44	34.82	37.21	39.60	41.98	44.37	46.76	108
114	4.08	6.64	9.21	11.77	14.33	16.90	19.46	22.02	24.58	27.15	29.71	32.27	34.84	37.40	39.96	42.53	45.09	47.65	50.22	114
120	4.27	6.95	9.64	12.32	15.01	17.69	20.37	23.06	25.74	28.42	31.11	33.79	36.48	39.16	41.84	44.53	47.21	49.89	52.58	120

CFL-D-6 Selection and Examples

Example 1:

Airflow given as 10,000 cfm - select louver size.

- A. Determine louver free area by dividing airflow by free area velocity (do not exceed 1158 fpm on intake louver application).

$$10,000 \text{ cfm} \div 1158 \text{ fpm} = 8.63 \text{ ft.}^2$$

Airflow	Free Area Velocity	Required Louver Free Area

- B. Select a louver with at least the required louver free area from Free Area Chart above.

78"W x 36"H

8.63 ft. free area

1158 fpm free area velocity (10,000) cfm ÷

8.63 ft.² F.A.

(Other selections available - See Free Area Chart above.)

- C. Check the pressure drop of the selected louver

at the selected louver given airflow (Airflow Resistance Chart on Page 2).

Δ P at 1158 fpm = 0.094 in w.g.

Free Area Velocity	Pressure Drop

Example 2:

Louver size given as 42 x 84 intake - determine maximum airflow.

- A. Use Free Area Chart to determine

$$\text{Free Area} = \underline{12.06} \text{ ft.}^2$$

- B. Multiply Free Area x Free Area Velocity (do not exceed 1158 fpm on intake louver applications).

$$\underline{12.06} \text{ ft}^2 \times \underline{1158} \text{ fpm} = \underline{13,965} \text{ cfm}$$

Free Area	Free Area Velocity	Maximum Airflow

- C. Check the pressure drop of the selected

louver at the given airflow (Airflow

Resistance Chart on Page 2).

D P at 1158 fpm = 0.094 in w.g.

Free Area Velocity	Pressure Drop