

FIXED LOUVER 6"

APPLICATION AND FEATURES

The MODEL EL-6 is a weather louver designed to protect the outside opening in building exterior walls. These louvers may be used for exhaust or intake air.

Standard Construction:

Frame: .125 Extruded Aluminum, 6.20" Deep

Blade: .110 Extruded Aluminum positioned on a 45° angle on approximately 4.625" centers

Birdscreen: 3/4" x .051" Flattened Aluminum in removable frame. Screen is mounted as standard on inside (rear) looking from exterior of building.

Finish: Mill Aluminum (Std.)

Minimum Size: 12 x12

Maximum Single Section: 120"w x 84"h or 84"w x 120"h

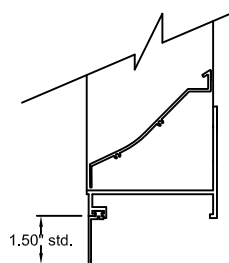
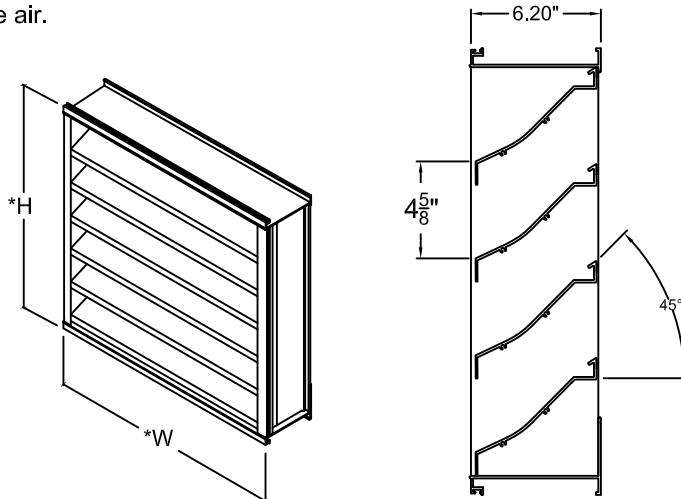

OPTIONAL FLANGE

Options:

- Flanged Frame (1-1/2" std.)
- Custom Flange (1", 2", or 3")
- Glazing Adapter (1/2" or 3/4")
- Extended Sill
- Insect Screen
- Filter Racks
- Security Bars
- Hinged Sub Frame
- Welded Const. (wind load 50 p.s.f.)

Finishes:

- Clear Anodize
- Integral Color Anodize
- Baked Powder Polyester
- Baked Powder Fluoropolymer 70%
- Baked Powder Clear Coat

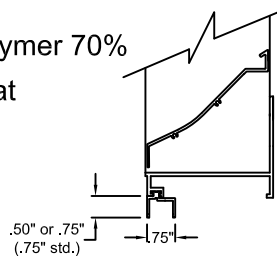

OPTIONAL GLAZING ADAPTER

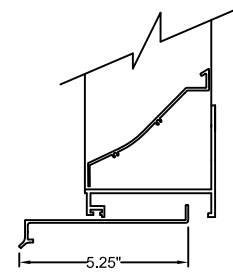

OPTIONAL EXTENDED SILL

*Width and Height dimensions are approximately 1/4" under listed size.

Job Name:	<input type="checkbox"/> MODEL EL-6		
Location:	DRAWN BY: SRB	DATE: November 2006	REV. DATE: January 2009
Architect:	REV. NO. 5	APPROVED BY: BGT	DWG. NO.: E-2c
Engineer:			
Contractor:			

SUGGESTED SPECIFICATION

Furnish and install louvers as hereinafter specified where shown on plans or as described in schedules. Louvers shall be "J" blade style with 45° stationary blades. Stationary blades shall be contained within a 6.20" frame. Louver components (heads, jambs, sills, blades, and mullions) shall be factory assembled by the louver manufacturer. Louver sizes too large for shipping shall be built up by the contractor from factory assembled louver sections to provide overall sizes required. Louver design shall incorporate structural supports required to withstand a wind load of 25 lbs. Per sq. ft. (equivalent of a 100 mph).

Louvers shall be United Enertech #EL-6 with 6063T6 extruded aluminum construction as follows:
 Frame: 6.20" deep, .081" nominal wall thickness.
 Blades: .110" nominal wall thickness. Non-Drainable. Blades are positioned at 45-degree angle and spaced approximately 4.625" center to center.
 Screen: 3/4" x .051" (19 x 1.3) expanded, flattened aluminum in removable frame.
 Finish: Select finish specification from United Enertech Finishes Brochure.

Published louver performance data bearing the AMCA Certified Ratings Seal for Air Performance & Water Penetration must be submitted for approval prior to fabrication and must demonstrate pressure drop and water penetration equal to or less than the United Enertech model specified.

PERFORMANCE DATA

AMCA Standard 500 provides a reasonable basis for testing and rating louvers. Testing to AMCA 500 is performed under a certain set of laboratory conditions. This does not guarantee that other conditions will not occur in the actual environment where louvers must operate.

The louver system should be designed with a reasonable safety factor for louver performance. To ensure protection from water carryover, design with a performance level somewhat below maximum desired pressure drop and .01 oz./sq.ft. of water penetration.

Beginning point of WATER PENETRATION
 is
 834 fpm

free area velocity at .01 oz. of water penetration

WATER PENETRATION



United Enertech Corporation certifies that the EL-6 shown herein is licensed to bear the AMCA Seal. The ratings shown are based on tests and procedures performed in accordance with AMCA Publication 511 and comply with the requirements of the AMCA Certified Ratings Program. The AMCA certified rating seal applies to air performance ratings and water penetration ratings.

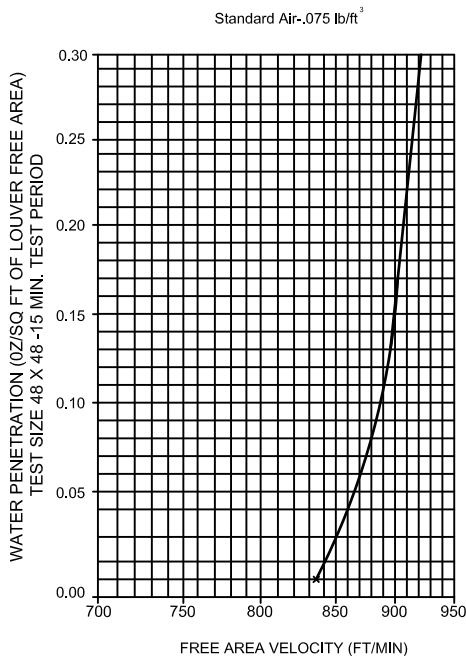

PRESSURE DROP

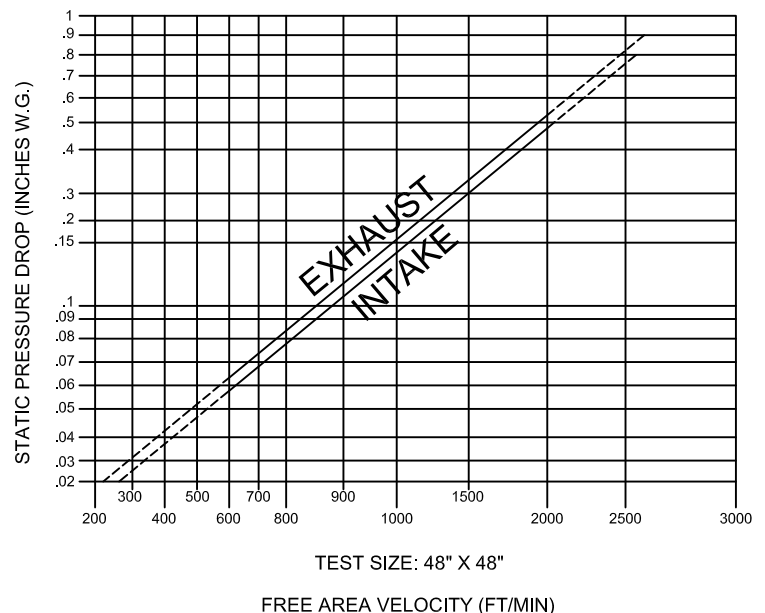

TEST SIZE: 48" X 48"
 FREE AREA VELOCITY (FT/MIN)
 Based on STANDARD AIR- .075 lb. per cubic foot.
 Ratings do not include the effects of screen.
 15 minute test duration

Louver Selection and Application

MODEL EL-6 FREE AREA CHART (SQUARE FEET)

Louver Height Inches	Louver Width In Inches																		Louver Height Inches	
	12	18	24	30	36	42	48	54	60	66	72	78	84	90	96	102	108	114		120
12	0.52	0.77	1.03	1.29	1.55	1.81	2.07	2.32	2.58	2.84	3.10	3.36	3.61	3.87	4.13	4.39	4.65	4.90	5.16	12
18	0.77	1.16	1.55	1.94	2.32	2.71	3.10	3.48	3.87	4.26	4.65	5.03	5.42	5.81	6.20	6.58	6.97	7.36	7.74	18
24	1.03	1.55	2.07	2.58	3.10	3.61	4.13	4.65	5.16	5.68	6.20	6.71	7.23	7.74	8.26	8.78	9.29	9.81	10.33	24
30	1.29	1.94	2.58	3.23	3.87	4.52	5.16	5.81	6.45	7.10	7.74	8.39	9.03	9.68	10.33	10.97	11.62	12.26	12.91	30
36	1.55	2.32	3.10	3.87	4.65	5.42	6.20	6.97	7.74	8.52	9.29	10.07	10.84	11.62	12.39	13.16	13.94	14.71	15.49	36
42	1.81	2.71	3.61	4.52	5.42	6.32	7.23	8.13	9.03	9.94	10.84	11.74	12.65	13.55	14.46	15.36	16.26	17.17	18.07	42
48	2.07	3.10	4.13	5.16	6.20	7.23	8.26	9.29	10.33	11.36	12.39	13.42	14.46	15.49	16.52	17.55	18.59	19.62	20.65	48
54	2.32	3.48	4.65	5.81	6.97	8.13	9.29	10.45	11.62	12.78	13.94	15.10	16.26	17.42	18.59	19.75	20.91	22.07	23.23	54
60	2.58	3.87	5.16	6.45	7.74	9.03	10.33	11.62	12.91	14.20	15.49	16.78	18.07	19.36	20.65	21.94	23.23	24.52	25.81	60
66	2.84	4.26	5.68	7.10	8.52	9.94	11.36	12.78	14.20	15.62	17.04	18.46	19.88	21.30	22.72	24.13	25.55	26.97	28.39	66
72	3.10	4.65	6.20	7.74	9.29	10.84	12.39	13.94	15.49	17.04	18.59	20.13	21.68	23.23	24.78	26.33	27.88	29.43	30.98	72
78	3.36	5.03	6.71	8.39	10.07	11.74	13.42	15.10	16.78	18.46	20.13	21.81	23.49	25.17	26.85	28.52	30.20	31.88	33.56	78
84	3.61	5.42	7.23	9.03	10.84	12.65	14.46	16.26	18.07	19.88	21.68	23.49	25.30	27.10	28.91	30.72	32.52	34.33	36.14	84
90	3.87	5.81	7.74	9.68	11.62	13.55	15.49	17.42	19.36	21.30	23.23	25.17	27.10	29.04	30.98	32.91	34.85	36.78	38.72	90
96	4.13	6.20	8.26	10.33	12.39	14.46	16.52	18.59	20.65	22.72	24.78	26.85	28.91	30.98	33.04	35.11	37.17	39.24	41.30	96
102	4.39	6.58	8.78	10.97	13.16	15.36	17.55	19.75	21.94	24.13	26.33	28.52	30.72	32.91	35.11	37.30	39.49	41.69	43.88	102
108	4.65	6.97	9.29	11.62	13.94	16.26	18.59	20.91	23.23	25.55	27.88	30.20	32.52	34.85	37.17	39.49	41.82	44.14	46.46	108
114	4.90	7.36	9.81	12.26	14.71	17.17	19.62	22.07	24.52	26.97	29.43	31.88	34.33	36.78	39.24	41.69	44.14	46.59	49.04	114
120	5.16	7.74	10.33	12.91	15.49	18.07	20.65	23.23	25.81	28.39	30.98	33.56	36.14	38.72	41.30	43.88	46.46	49.04	51.63	120

EL-6 Selection Examples

Example 1:

Airflow given as 10,000 cfm - select louver size

- A. Determine louver free area by dividing airflow by free area velocity (do not exceed 812 fpm on intake louver application)

$$10,000 \text{ cfm} / 750 \text{ fpm} = 13.3 \text{ sq.ft.}$$

Airflow F.A.V. Req'd. Louver Free Area

- B. Select a louver with at least the required louver free area from the Free Area Chart Above.

90"W x 54"H
17.42 ft. free area
750 fpm free area velocity (10,000) cfm / 17.42 sq.ft. F.A.
(Other selections available - See Free Area Chart above.)

- C. Check the pressure drop of the selected louver at the selected louver given airflow (Airflow Resistance Chart on page 2.)

$$\Delta P \text{ at } 750 \text{ fpm} = 0.07 \text{ in. w.g.}$$

F.A.V. Pressure Drop

Example 2:

Louver size given 42"W x 72"H intake - determine maximum airflow.

- A. Use Free Area Chart to determine
Free Area = 10.84 sq. ft.

- B. Multiply Free Area x Free Area Velocity (do not exceed 812 fpm on intake louver applications).

$$10.84 \text{ sq. ft.} \times 750 \text{ fpm} = 8,130 \text{ cfm}$$

Free Area F.A.V. Max Airflow

- C. Check the pressure drop of the selected louver at the given airflow (Airflow Resistance Chart on page 2).

$$D P \text{ at } 750 \text{ fpm} = 0.07 \text{ in. w.g.}$$