

**APPLICATION AND FEATURES**

The MODEL D-DR-4 is a weather louver designed to protect the outside opening in building exterior walls. These louvers may be used for exhaust or intake air. This model incorporates dual drainable blades and dual downspout jambs and gutter design for high performance.

**Standard Construction:**

**Frame:** .081" Extruded Aluminum, 4.20" Deep

**Blade:** .094" Extruded Aluminum positioned on a 39° angle on approximately 4.25" centers

**Bldscreen:** 3/4" x .051" Flattened Aluminum in removable frame. Screen is mounted as standard on inside (rear) as looking from exterior of building.

**Finish:** Mill Aluminum (Std.)

**Minimum Size:** 9 x 9

**Maximum Single Section:** 84"w x 120"h or 120"w x 84"h

**Note:** Drainable blade louvers should be limited to 10' maximum section widths (no more than 10' between vertical downspouts) to enable the drainable design to function effectively.

**Options:**

- Flanged Frame (1-1/2" std.)
- Custom Flange (1", 2", or 3")
- Glazing Adapter (1/2" or 3/4")
- Extended Sill
- Insect Screen
- Filter Racks
- Security Bars
- Hinged Sub Frame
- Welded construction (wind load 50 p.s.f.)

**Finishes:**

- Clear Anodize
- Integral Color Anodize
- Baked Powder Polyester
- Baked Powder Fluoropolymer 70%
- Baked Powder Clear Coat

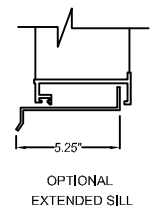
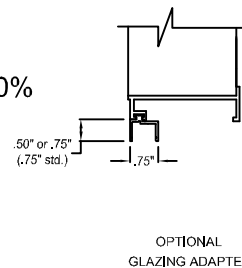
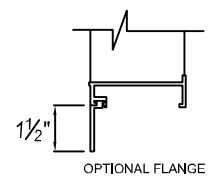
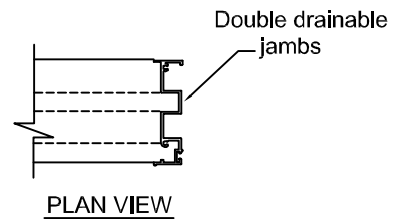
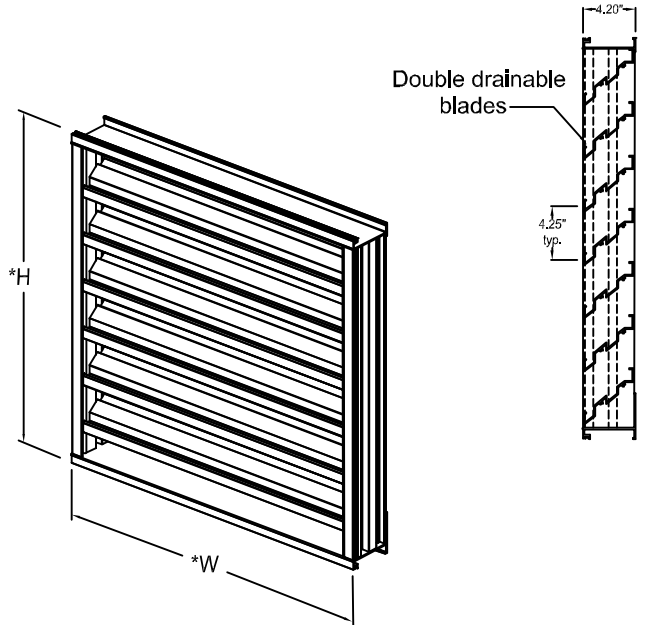

\*Width and Height dimensions are approximately 1/4" under listed size.

Job Name:	<input type="checkbox"/> <b>MODEL D-DR-4</b>		
Location:			
Architect:	DRAWN BY: CLJ	DATE: DECEMBER 2006	REV. DATE: JANUARY 2009
Engineer:	REV. NO. 2	APPROVED BY: BGT	DWG. NO.: <b>E-1a</b>
Contractor:			

# SUGGESTED SPECIFICATION

Furnish and install louvers as hereinafter specified where shown on plans or as described in schedules. Louvers shall be stationary drainable type with drain gutters in each blade and downspouts in jambs and mullions. Stationary drainable blades shall be contained within a 4.20" frame. Louver components (heads, jambs, sills, blades, and mullions) shall be factory assembled by the louver manufacturer. Louver sizes too large for shipping shall be built up by the contractor from factory assembled louver sections to provide overall sizes required. Louver design shall incorporate structural supports required to withstand a wind load of 25 lbs. Per sq. ft. (equivalent of a 100 mph wind)

Louvers shall be United Enertech #D-DR-4 6063T6 extruded aluminum construction as follows:

- Frame: 4.20" deep, .125 nominal wall thickness.
- Blades: .081 nominal wall thickness. Drainable.
- Blades are positioned at 39-degree angle and spaced approximately 4.25" center to center.
- Screen: 3/4" x .051" (19 x 1.3) expanded, flattened aluminum in removable frame.
- Finish: Select finish specification from United Enertech Finishes Brochure.

Published louver performance data bearing the AMCA Certified Ratings Seal for Air Performance & Water Penetration must be submitted for approval prior to fabrication and must demonstrate pressure drop and water penetration equal to or less than the United Enertech model specified.

# PERFORMANCE DATA

AMCA Standard 500 provides a reasonable basis for testing and rating louvers. Testing to AMCA 500 is performed under a certain set of laboratory conditions. This does not guarantee that other conditions will not occur in the actual environment where louvers must operate.

The louver system should be designed with a reasonable safety factor for louver performance. To ensure protection from water carryover, design with a performance level somewhat below maximum desired pressure drop and .01 oz./sq.ft. of water penetration.

Beginning point of WATER PENETRATION  
is  
1157 fpm

free area velocity at .01 oz. of water penetration



United Enertech certifies that the D-DR-4 shown herein is licensed to bear the AMCA Seal. The ratings shown are based on tests and procedures performed in accordance with AMCA Publication 511 and comply with the requirements of the AMCA Certified Ratings Program. The AMCA certified rating seal applies to air performance ratings and water penetration ratings.

## WATER PENETRATION

Standard Air-.075 lb/ft<sup>3</sup>

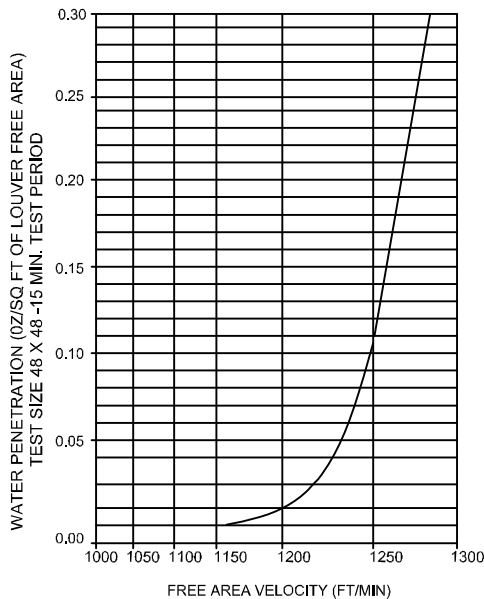

## PRESSURE DROP

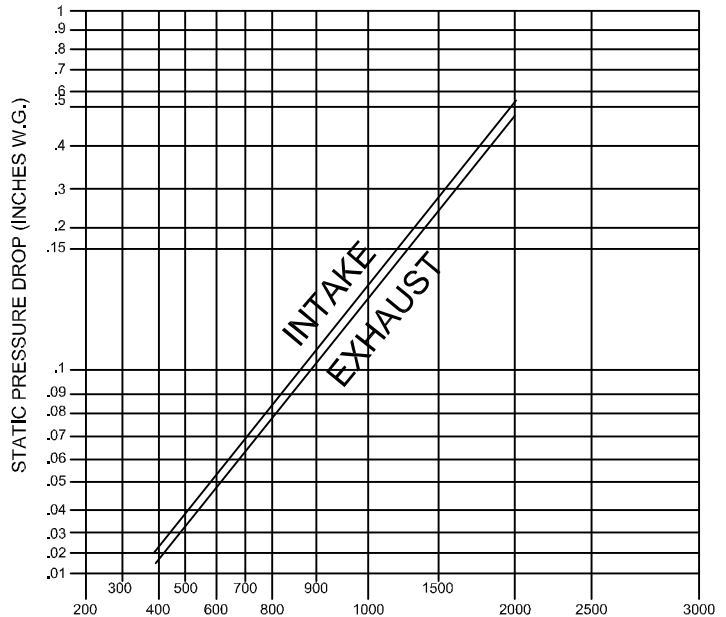

TEST SIZE: 48" X 48"

FREE AREA VELOCITY (FT/MIN)

Based on STANDARD AIR-.075 lb. per cubic foot.  
Ratings do not include the effects of screen.  
15 minute test duration

# Louver Selection and Application

## MODEL D-DR-4 FREE AREA CHART (SQUARE FEET)

Height - Inches	Width - Inches																		Louver Height Inches	
	12	18	24	30	36	42	48	54	60	66	72	78	84	90	96	102	108	114		120
12	0.28	0.45	0.63	0.80	0.97	1.15	1.32	1.49	1.67	1.84	2.01	2.18	2.36	2.53	2.70	2.88	3.05	3.22	3.40	12
18	0.44	0.71	0.97	1.24	1.51	1.78	2.05	2.32	2.59	2.86	3.13	3.39	3.66	3.93	4.20	4.47	4.74	5.01	5.28	18
24	0.56	0.91	1.25	1.60	1.94	2.28	2.63	2.97	3.32	3.66	4.01	4.35	4.70	5.04	5.39	5.73	6.08	6.42	6.77	24
30	0.85	1.37	1.89	2.41	2.93	3.45	3.98	4.50	5.02	5.54	6.06	6.58	7.11	7.63	8.15	8.67	9.19	9.71	10.23	30
36	1.00	1.62	2.24	2.86	3.47	4.09	4.71	5.33	5.94	6.56	7.18	7.80	8.41	9.03	9.65	10.27	10.88	11.50	12.12	36
42	1.32	2.14	2.95	3.76	4.58	5.39	6.20	7.02	7.83	8.64	9.46	10.27	11.08	11.90	12.71	13.52	14.34	15.15	15.96	42
48	1.48	2.39	3.30	4.21	5.12	6.03	6.94	7.85	8.76	9.67	10.58	11.49	12.40	13.31	14.21	15.12	16.03	16.94	17.85	48
54	1.61	2.59	3.58	4.57	5.56	6.54	7.53	8.52	9.51	10.50	11.48	12.47	13.46	14.45	15.43	16.42	17.41	18.40	19.39	54
60	1.89	3.05	4.21	5.37	6.54	7.70	8.86	10.02	11.18	12.35	13.51	14.67	15.83	17.00	18.16	19.32	20.48	21.64	22.81	60
66	1.90	3.06	4.23	5.40	6.57	7.73	8.90	10.07	11.24	12.40	13.57	14.74	15.91	17.07	18.24	19.41	20.58	21.74	22.91	66
72	2.19	3.53	4.88	6.22	7.57	8.92	10.26	11.61	12.95	14.30	15.64	16.99	18.34	19.68	21.03	22.37	23.72	25.06	26.41	72
78	2.35	3.79	5.24	6.68	8.12	9.57	11.01	12.46	13.90	15.35	16.79	18.24	19.68	21.12	22.57	24.01	25.46	26.90	28.35	78
84	2.65	4.28	5.91	7.54	9.17	10.80	12.44	14.07	15.70	17.33	18.96	20.59	22.22	23.85	25.48	27.11	28.74	30.38	32.01	84
90	2.82	4.56	6.30	8.03	9.77	11.51	13.24	14.98	16.72	18.46	20.19	21.93	23.67	25.40	27.14	28.88	30.61	32.35	34.09	90
96	2.94	4.75	6.56	8.37	10.18	11.99	13.80	15.61	17.42	19.23	21.04	22.85	24.67	26.48	28.29	30.10	31.91	33.72	35.53	96
102	3.23	5.22	7.21	9.20	11.19	13.18	15.16	17.15	19.14	21.13	23.12	25.11	27.10	29.09	31.07	33.06	35.05	37.04	39.03	102
108	3.39	5.47	7.55	9.64	11.72	13.80	15.89	17.97	20.05	22.14	24.22	26.31	28.39	30.47	32.56	34.64	36.72	38.81	40.89	108
114	3.50	5.65	7.80	9.95	12.10	14.25	16.41	18.56	20.71	22.86	25.01	27.16	29.32	31.47	33.62	35.77	37.92	40.07	42.23	114
120	3.67	5.93	8.19	10.45	12.71	14.97	17.23	19.49	21.75	24.00	26.26	28.52	30.78	33.04	35.30	37.56	39.82	42.08	44.34	120

### D-DR-4 Selection Examples

#### Example 1:

Airflow given as 10,000 cfm - select louver size

- A. Determine louver free area by dividing airflow by free area velocity (do not exceed 1157 fpm on intake louver application)

$$10,000 \text{ cfm} / 900 \text{ fpm} = 11.1 \text{ sq.ft.}$$

Airflow            F.A.V.      Req'd. Louver Free Area

- B. Select a louver with at least the required louver free area from the Free Area Chart Above.

60"W x 66"H

11.24 sq. ft. free area

900 fpm free area velocity (10,000) cfm / 11.24 sq.ft. F.A.  
(Other selections available - See Free Area Chart above.)

- C. Check the pressure drop of the selected louver at the selected louver given airflow (Airflow Resistance Chart on page 2.)

$$\Delta P \text{ at } 900 \text{ fpm} = 0.12 \text{ in. w.g.}$$

F.A.V.            Pressure Drop

#### Example 2:

Louver size given 48"W x 72"H intake - determine maximum airflow.

- A. Use Free Area Chart to determine  
Free Area = 10.26 sq. ft.

- B. Multiply Free Area x Free Area Velocity (do not exceed 1157 fpm on intake louver applications).

$$10.26 \text{ sq. ft.} \times 900 \text{ fpm} = 9,234 \text{ cfm}$$

Free Area    F.A.V.            Max Airflow

- C. Check the pressure drop of the selected louver at the given airflow (Airflow Resistance Chart on page 2).

$$D P \text{ at } 900 \text{ fpm} = 0.12 \text{ in. w.g.}$$