

STAR SERIES

STANDARD CONSTRUCTION:

OUTRIGGER & BRACKET:

- .25" Aluminum (standard)
- .375" Aluminum (optional)

BLADES:

.108" Aluminum Airfoil, 2" deep x 8" wide positioned on a 35° angle on approximately 7-13/16" centers.

FINISH:

mill aluminum (std.)

MAXIMUM SIZE:

72" Projection x 120" Length (single section)
 *Intermediate blade support may be required.

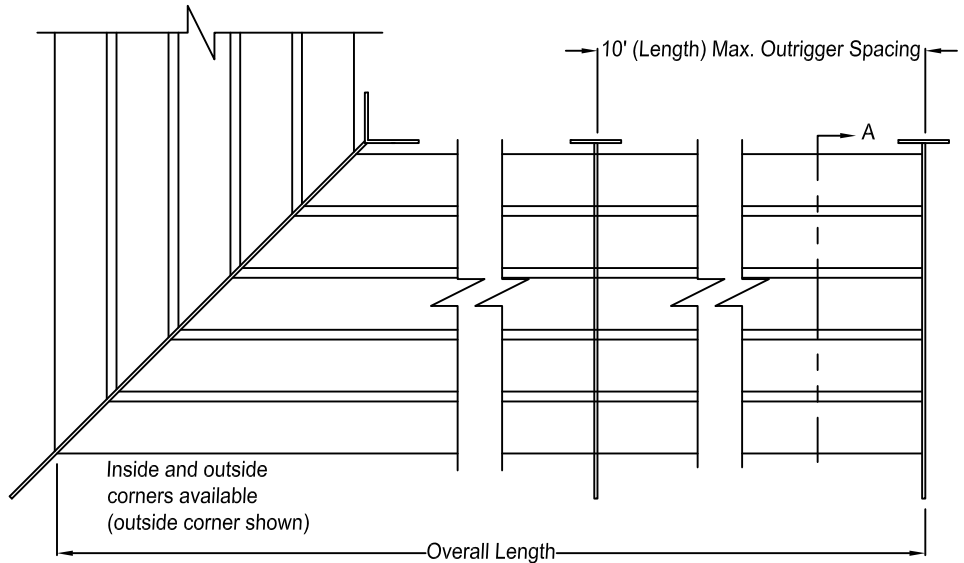

OPTIONAL FINISHES:

- Powder Polyester TGIC** (2 coats) baked on at 410°F -2.5 to 3.5 mils Meets AAMA-2603 Standards
- Powder Super durable polyester** (2 coats) baked on at 410°F -2.5 to 3.5 mils Meets AAMA-2604-05 Standards
- Acrylic baked enamel (ACRA-BOND® ULTRA)** by AkzoNobel baked on at 350°F -0.8 to 1.2 mils dry Meets AAMA-2603 Standards
- Kynar® (ALUM*A*STAR®)** 2 coats by AkzoNobel baked on at 450°F -1.2 to 1.6 mils dry Meets AAMA-2605-05 Standards
- Kynar 500®** or **HYLAR® 5000 70% TRINAR®** (2 coats) by AkzoNobel baked on at 450°F -1.2 to 1.6 mils dry, Meets AAMA-2605-05 Standards
- Kynar 500®** or **HYLAR® 5000 (70% Tri-Escent II)** (2 coats) by AkzoNobel, a superior finish to other metallic or anodized finishes. A blend of mica, ceramic, and inorganic pigments creates subtle yet dazzling design that goes beyond metallic color without the requirement of a clear coat. 14 standard colors - custom colors available. Baked on at 415°F -1.4 to 1.8 mils dry, meets AAMA 2605-05.
- Clear Anodize 204 R-1 Class II (AA-C22A31)**(0.4 to 0.7 mil)
- Clear Anodize 215 R-1 Class I (AA-C22A41)**(>0.7 mil)
- Integral Color Anodize (AA-C22A42)**(>0.7 mil)
 - Clear coat available for all above finishes.
 - Hylar® 5000 is a registered trademark of Solvay Solexis, Inc.
 - Kynar® 500 is a registered trademark of Arkema.
 - ALUM*A*STAR® 50 and TRINAR® are registered trademarks of AkzoNobel
 - ACRA-BOND® ULTRA is a registered trademark of AkzoNobel

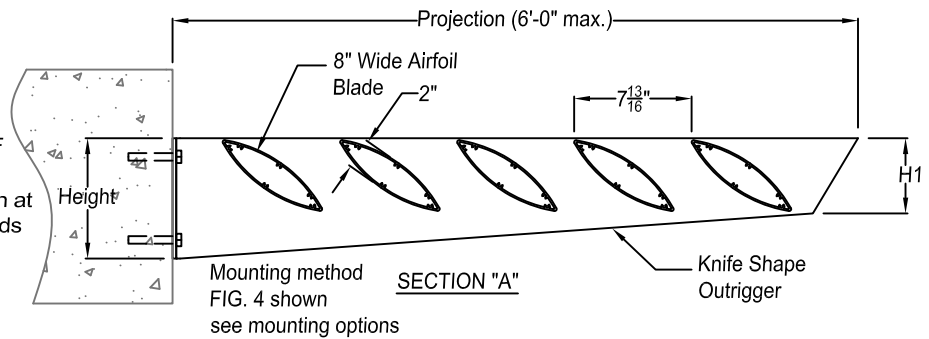

3 part specifications - see online at www.unitedenertech.com



Due to continuing research, United Enertech reserves the right to change specifications without notice.

QUANTITY	LENGTH	HEIGHT	H1	PROJECTION	TAG



3005 South Hickory Street
 Chattanooga, Tennessee 37407
 Tel: (423) 698-7715
 Fax: (423) 698-6629
www.unitedenertech.com

STAR SERIES

DRAWN BY:	DATE:	REV. DATE:	REV. NO.	APPROVED BY:	DWG. NO.:
CLJ	1-13-10	5-18-10	3	BGT	C-1