

## Application

Brick vents provide a permanent means of ventilation for crawl spaces, hung ceilings, incinerator rooms, chimney flues, foundations, pipe spaces, and corridors. Extruded construction provides a quality finished appearance. Water stops and deep overlapping blades, each with integral storm drip, provide maximum resistance to rain and weather.

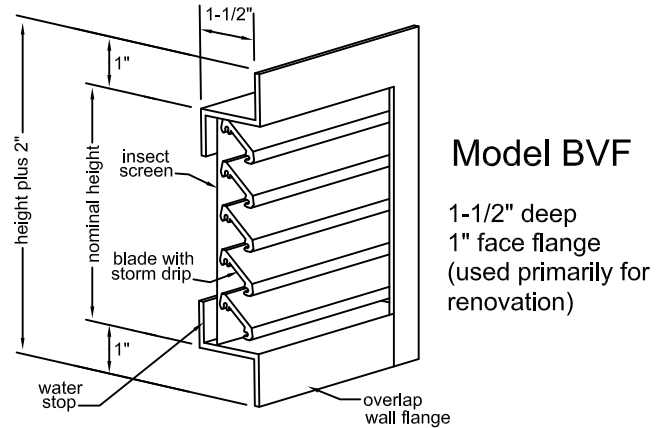
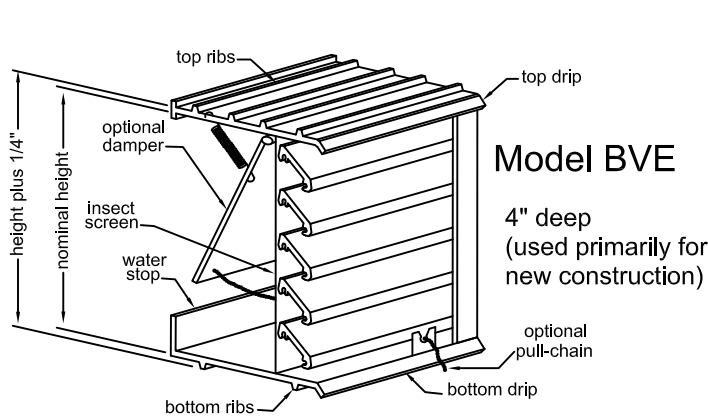

## Standard Construction

Frame: Heavy gauge 6063T5 extruded aluminum, .125" nominal wall thickness. Model BVE frame is 4" deep with 1/8" mortar ribs top and bottom (adding 1/4" to nominal height). Model BVF frame is 1-1/2" deep (fastener heads add 1/4" to nominal width).

Blades: Heavy gauge 6063T5 extruded aluminum, .125" nominal wall thickness. 45° blades overlap for optimum visual screening

Screen: 18 x16 mesh aluminum insect screen

Finish: Clear Anodized

Sizes Available: Standard sizes shown below. Other sizes available to maximum of 96"x 96"

## Options (at additional cost)

Single blade damper with stainless steel spring and stainless steel pull chain. (Models BVE & BVF)

Straight Duct: .063 aluminum (for up to 12" wall thickness)

Anodizing: Medium Bronze, or Dark Bronze

Powder Coating:  Standard super durable polyester

70% Fluoropolymer

QUANTITY	BVE	BVF	MODEL	NOMINAL SIZE	FREE AREA (SQ. FT.)	OPTIONS/ACCESSORIES/VARIATIONS
			825	8-1/8" X 2-3/8"	.036	
			847	8-1/8" X 4-3/4"	.082	
			808	8-1/8" X 7-3/4"	.170	
			123	12" X 2-3/8"	.056	
			125	12" X 4-3/4"	.125	
			128	12" X 7-3/4"	.236	
			1212	12" X 11-3/4"	.351	
			157	15-5/8" X 7-3/4"	.295	
			1516	15-5/8" X 15-3/4"	.627	
			162	16-1/2" X 2-3/8"	.078	
			164	16-1/2" X 4-3/4"	.184	
			168	16-1/2" X 7-3/4"	.313	
			1616	16-1/2" X 15-3/4"	.664	
			242	24" X 2-3/8"	.118	
			244	24" X 4-3/4"	.259	
			248	24" X 7-3/4"	.461	
			3208	32" X 7-3/4"	.620	
			4808	48" X 7-3/4"	.938	

Job Name:	<input type="checkbox"/> MODEL BVE		
Location:	<input type="checkbox"/> MODEL BVF		
Architect:	DRAWN BY:	DATE:	REV. DATE:
Engineer:	CLJ	12-1-99	02-26-09
Contractor:	REV. NO.:	APPROVED BY:	DWG. NO.:
	6	BGT	E-15