

MANUAL BALANCING DAMPERS
Heavy Duty 16 Ga. Steel Blade

OPPOSED BLADE - PARALLEL BLADE BALANCING DAMPER

Suggested Specifications:

Furnish and install at location shown on drawing or in accordance with scheduled balancing dampers meeting the following specifications: Rectangular damper shall have 16 gauge galvanized steel blades with galvanized steel rollformed frames. Damper to be equal to United Enertech MODEL MD-115 or MD-116.

Ratings:

Pressure - up to 4" w.g.

FPM Table

12" wide	- 3500 FPM
24"	- 2800
36"	- 2300
48"	- 2100

Standard Features:

Frame: Rollformed Galvanized Steel

Blades: 4"-7" wide, 16ga. Galvanized Steel

Bearing: Nylon

Linkage: Concealed in frame

Axles: 3/8" square plated steel

Control Shaft: Ø1/2" x 4-1/2" long shaft supplied with all hand quadrant operated dampers.

Hand Quadrant: Standard (field installed)

Options:

- Stand Off Bracket, 2"
- Side plate (end flange)

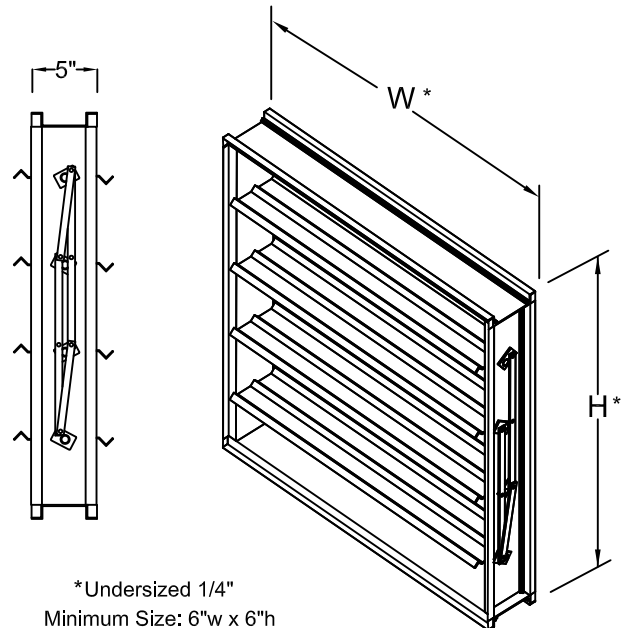

*Undersized 1/4"
 Minimum Size: 6"w x 6"h
 Maximum Size: 48"w x 60"h (single section only)
 9"h and under - single blade
 Maximum multi-section: NOT AVAILABLE

NOTE: THESE DAMPERS ARE FOR BALANCING PURPOSES ONLY. THEY ARE NOT FOR SHUT-OFF APPLICATIONS. GAPS BETWEEN BLADES & FRAME WILL EXIST.

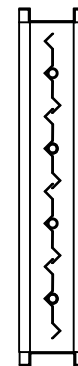

CROSS SECTIONAL VIEW
 Closed position

Job Name:	<input type="checkbox"/> MODEL MD-115 (Opposed)		
Location:	<input type="checkbox"/> MODEL MD-116 (Parallel)		
Architect:	DRAWN BY: CLJ	DATE: 10-1-08	REV. DATE: 07-27-09
Engineer:	REV. NO. 5	APPROVED BY: SDC	DWG. NO.: A-4a
Contractor:			

MODEL MD-115, 116 PERFORMANCE DATA

PRESSURE DROP

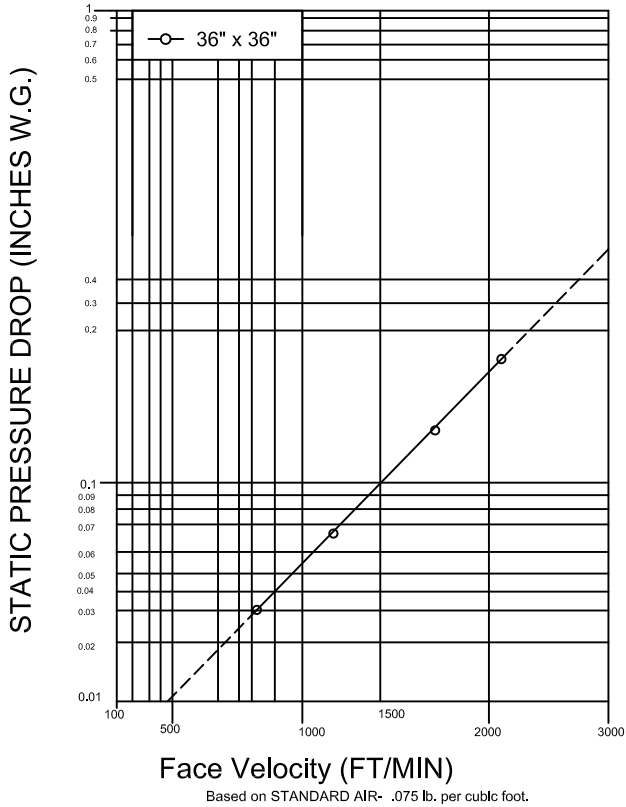

MD-115, 116 sizes: 36" x 36" (915mm x 915mm)

36 x 36	
Face Velocity ft/min (m/s)	Pressure Drop* in. w.g. (Pa)
1000 (5.08)	.04 (9.9)
1500 (7.62)	.08 (19.9)
2000 (10.16)	.16 (39.8)

*Full open position

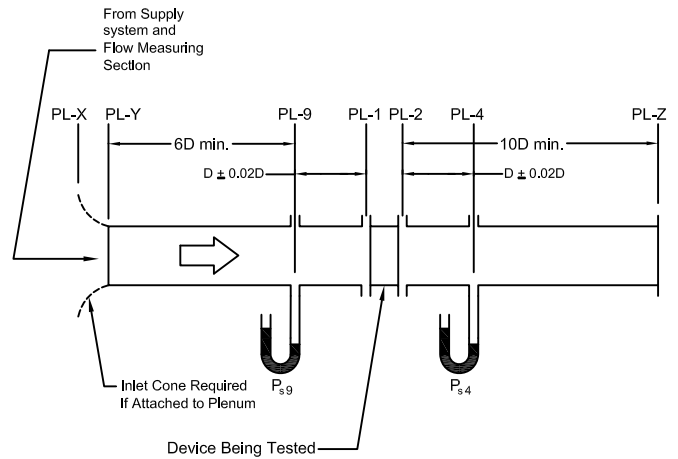

Figure 5.3- Test Device Setup with Inlet and Outlet Ducts

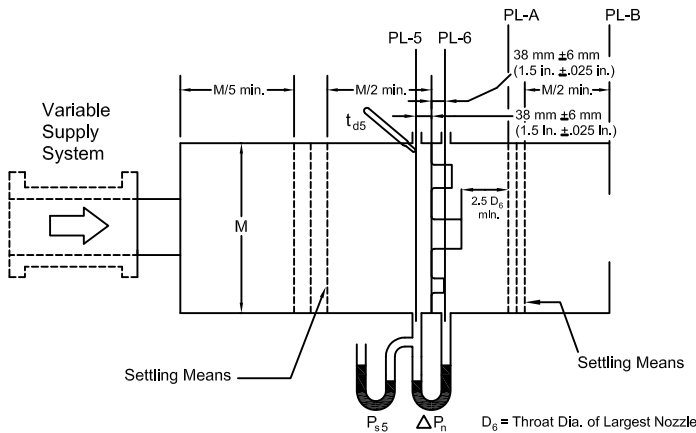

Figure 6.5- Airflow Rate Measurement Setup- Multiple Nozzle Chamber on Fan Outlet